

Northwest Atlantic



Fisheries Organization

Serial No. N7562

NAFO SCR Doc. 24/052

SCIENTIFIC COUNCIL AND STACFIS SHRIMP ASSESSMENT MEETING –SEPTEMBER 2024

The West Greenland trawl survey for *Pandalus borealis*, 2024, with reference to earlier results.

by

AnnDorte Burmeister and Tanja Buch

Greenland Institute of Natural Resources
Box 570, 3900 Nuuk, Greenland

Abstract

A trawl survey is carried out with the research vessel Tarajoq, in NAFO Subarea 1 and NAFO Division 0A east of 60°30'W, as a contribution to the assessment of the stock of the Northern Shrimp (*Pandalus borealis*). In 2024, 359 stations were fished in 49 fishing days; 291 stations provided data to the shrimp survey.

In 2024, there was no abnormal spatial distribution of sea ice north of 66°N in Greenland EEZ. However, due to an earlier start of the survey (mid May) than in the past years, ice coverage in some of the more Northwestern regions and in the Canadian area (SFA1), prevents trawling of planned stations during the survey. Results from the survey is nevertheless assumed to be representative for survey biomass, fishable biomass and densities and reflect the stock trajectory and status.

The overall survey biomass dropped (26%) compared to 2023 and is in 2024 (225 Kt), 67% of its past 5-yr mean, 77% of its past 10-yr mean and 76% its serial means (279 Kt). The offshore survey biomass (145 Kt) was lower compared to past years and is in 2024 below both its past 5-yr., past 10-yr. and serial mean. Highest biomasses are found in the more northern regions (U1-U3) and (W1-2), which constitutes 80% of the offshore biomass. The survey biomass (0.2 Kt) in the Canadian area (SFA1/C0) contributes with less than 0.5% of the total offshore biomass,

There was no problem with sea ice in Disko Bay & Vaigat, where survey biomass increased (80 Kt) and is in 2024 above its past 5-yr. mean (133%), and almost at its past 10-yr mean (115%). The offshore regions constitute 64% of the total surveyed biomass, and 36% of the biomass is in Disko Bay & Vaigat.

The Fishable proportion (94%) of the survey biomass is above the serial mean (92%). Both female and male biomass are well below its past means.

Numbers at age-2 shrimp are in total below its the serial mean and the numbers of pre-recruits (14-16.5 mm CL) in total are also below average in absolute numbers and relative to their biomass. The values of age-2 shrimp, and pre-recruits are higher in offshore regions than those of Disko Bay & Vaigat.



Survey biomass depth index has ranged between 265 and 300 m since 2001, with an average near 281.5 m compared to an average of 329 m in the period from 1988 to 2000. In 2020 and 2022 the depth index was estimated to approx. 255 m but was 269 m in 2023 and 277 in 2024 but is comparable with values of the past 5 year (279 m).

Area-weighted mean bottom temperature in the survey area increased at the beginning of the 1990s, by about 1.6°C, to 3.3°C in 1999. In the successive year's bottom temperature remain stable but starts a continuous decrease from 2015 to a low value at 2.1°C in 2018, followed by a continuous increase to 3.3°C.

Introduction

Since 1988, the Greenland Institute of Natural Resources has carried out annual trawl surveys on the West Greenland shelf between June and August to assess the biomass and recruitment of the stock of *Pandalus borealis* and to obtain information on the size and sex composition of the stock as well as on the environmental conditions. This document presents the results of the 2024 survey and compares it with revised series from previous surveys.

Material and Methods

Survey design and area coverage

The offshore survey area for the Northern shrimp, *Pandalus borealis*, covers waters on the West Greenland continental shelf from Kap Farvel in the south to latitude 72°30'N, comprising NAFO Subarea 1 and, where the shelf bulges into the Canadian EEZ, a small area in the eastern part of NAFO Div. 0A. In the late 1980s when the survey was initiated, *P. borealis* was fished in waters between about 150 m and 550 m deep, and the shrimp survey has always been restricted to depths between 150 m and 600 m. Since 1991 the survey has included the inshore areas of Disko Bay and Vaigat in NAFO Div. 1A but, along most of the coast, the survey does not cover areas closer to shore than 3 miles offshore of the fishery baseline. In some coastal areas fishable concentrations of *P. borealis* exist closer to shore than this, including areas that extend into some fjords (see e.g. Fig. 4a of Hammeken and Kingsley 2010).

The survey area is divided into primary and secondary strata. The survey primary strata correspond to geographical areas identified based on logbook information on the distribution of the fishery (Carlsson *et al.* 2000). They are subdivided into four secondary (depth) strata at 150–200 m, 200–300 m, 300–400 m, and 400–600 m. When the survey was initiated, bathymetric information in Disko Bay, as well as offshore north of 69°30'N, did not support this depth stratification, and these regions were therefore originally subdivided into geographical substrata not based on depth. Depth data logged by the survey and other investigations eventually allowed these waters to be stratified on depth and a new geographical stratification with depth sub-strata was introduced in 2004 (Wieland and Kannevorff, 2004). At the same time, the geographical strata in the Canadian zone, formerly two, were merged into one.

From 1988 through 1999, trawl stations were allocated to strata in proportion to stratum area, but since 2000 more stations have been allocated to strata where biomass variances have been high in previous years in order to improve the precision of the overall biomass estimate (Kingsley *et al.*, 1999). An exponential smoothing of previous years' stratum variances was applied in the allocation procedure, giving higher influence on the more recent years. Past variance data for Atlantic cod and Greenland halibut is also made available to the allocation procedure, which is now set to minimize a weighted combination of the expected survey precision for the three species.

Generally, the station layout is based on a division of the survey area into elements about 2 nautical miles square. Since 1999 survey stations have been positioned using 'buffered random' sampling, in which stations are placed randomly with the constraint that a minimum distance between them, which depends on station density within the stratum, must be observed (Kingsley *et al.*, 2004).

From 1988 through 1998, survey designs were independent from year to year, stations being placed anew in the strata. Since 1999 about 50% of the stations included in the preceding year's design have been repeated as fixed stations in the following year, the others being placed, as before, using the buffered sampling rules. Catches are correlated from

year to year by position, and fixing stations improves the ability of the survey to indicate year-to-year changes in stock size by inducing serial correlation in survey error (Kingsley, 2001a).

In 2024, 505 stations were planned at depths between 50 and 600 m in the survey area, 245 of those were 'extra' stations mapped and available to be included if time permitted. 357 of the planned stations incl. 'extra' stations were fished. 17 stations were discarded, either due to untrawlable bottom or owing to general trawl difficulties and 56 of the planned station were not fished due to ice coverage in U2, U1, W1, C0 and W10 . In 2024 there was not extraordinary ice coverage during the survey period, but due to the fact that the survey was conducted earlier in May and June than back in time. The Sea ice in the not covered area was too thick and prevented trawling.

Of the 357 stations fished, 291 provided usable data to the shrimp survey. In the course of the shrimp survey, CTD casts were made along standard transects offshore and in Disko Bay and Vaigat; and in 2024, no stations were fished with a beam trawl for benthos monitoring, but at 11 stations cod was tagged.

Survey period and daily sampling period

The trawl survey has been carried out every year between mid-June and the end of August to minimize the effect of seasonal cycles in the biology of the species. However, in 2023 the survey started May 22nd and ended July 11th. In 2024 the survey began May the 18th and was done July the 2nd. Trawling is carried out between 0800 and 2400 UTC; it appears that the daily vertical migration of the Northern shrimp is quite abrupt at sunrise and sunset. However, in 2023- and 2024-night stations are included in the assessment as well.

Tow duration

From 1988 to 1997 all tows in the shrimp survey lasted 60 min. However, shorter tows give just as accurate results (Carlsson *et al.*, 2000; Kingsley, 2001b; Kingsley *et al.*, 2002; Wieland and Storr-Paulsen, 2006; Ziemer and Siegstad, 2009) and since 2005 the survey has been operated with 15-minute tows alone.

Fishing practices

The surveys have been conducted with the research trawler *Paamiut* (722 GRT) since 1991, similar vessels were used in 1988–1990. However, in the beginning of 2018 it was decided that the old research vessel *Paamiut* must be scraped owing to increasing expenses to maintenance. Instead, the survey was conducted with a chartered fishing vessel *Sjudarberg* in 2018 and *Helga Maria* in 2019 and 2020. All fishing gear were removed from *Paamiut* and installed at the chartered vessels, both in 2018, 2019 and 2020. Fishing practice and handling of catch were exactly as used on the research ship *Paamiut* (See appendix 1). Since 2022, surveys have been conducted with the new research ship *Tarajoq*. All gear, fishing practices and handling of catches were exactly as used on *Paamiut*.

Initially, a 3000/20-mesh *Skjervøy* bottom trawl with a twin cod-end, and equipped with a heavy steel-bobbin footrope, was used. A 20-mm (stretched-mesh) liner was added to the 44-mm-mesh cod-end in 1993. From 1988 to 1991 estimates of trawl geometry—door spread and height of head-rope—were based on results from tank experiments at the Danish Institute for Fisheries Technology and Aquaculture. Since 1991 *Scanmar* acoustic sensors have been mounted on the trawl doors, and a *Furuno* trawl-eye on the head rope. Door-spread readings are recorded during the tow, and the reading from the trawl-eye is used to judge when the trawl has settled, and the tow can be deemed started.

From 1988 through 2003 *Greenland Perfect* trawl doors were used, measuring 9.25 m² and weighing 2420 kg. They were replaced in 2004 by *Injector International* 7.5 m² trawl doors weighing 2800 kg to facilitate a change of survey trawl in 2005. In 2005 the *Skjervøy* 3000 trawl was replaced by a *Cosmos* 2000 trawl with 'rock-hopper' ground gear comprising steel bobbins and rubber disks. Towing speeds have been about 2.5 knots in all surveys. A new *Cosmos* trawl, with identical dimensions as the old one, has been used during the survey since 2022. No differences in catchability were observed.

Swept area calculation

Nominal swept area for each tow was calculated as the straight-line distance between its GPS start and end positions multiplied by the wingspread. The distance between the trawl doors should be recorded 3 or 5 times during each tow; provided it was recorded at least once, wingspread for a tow was calculated from the mean door spread and the geometry of the trawl. For both trawls the wingspread (i.e. the width of the swept area) V has been calculated as follows. The trawl and the trawl plus bridles are assumed to form two similar triangles, bridles and wings making a straight line:

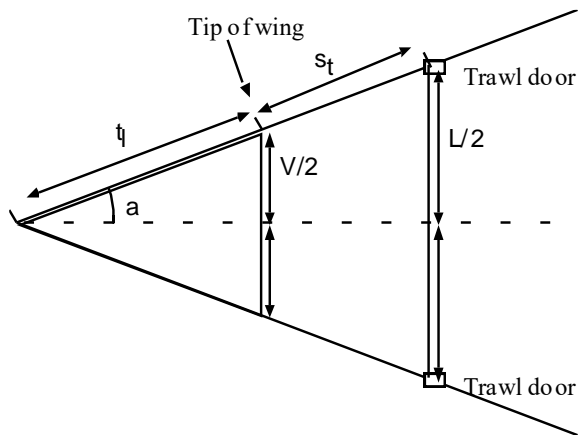

and the lengths of the bridles (s) and the trawl wings (t) are known. The wingspread V is then calculated as:

$$V = (t_t * L) / (t_t + s_t)$$

where L is the distance between the doors (door spread).

The length of the *Skjervøy* trawl is 67.15 m and the length of the *Cosmos* trawl is 71 m, both measures excluding the cod-ends. Since 2004 the bridle length, i.e. the total length of lines, chains and shackles between the trawl doors and the tip of the trawl wing, has been 54 m for either trawl; other bridle lengths were used in earlier years (Table 1). In the case of the *Skjervøy* trawl, 0.7 m has been added to the calculated wingspread because the *Skjervøy* trawl is a three-winged trawl and the lower wings (directly attached to the ground-rope) were estimated to spread 0.35 meters wider than the middle wings on each side in tank experiments at the Danish Institute for Fisheries Technology and Aquaculture (Per Kannevorff, pers. com.).

If door spread was not recorded during a tow, the unweighted mean of the calculated wingspreads for the year was used, without regard to fishing depth or wire length. If the speed of the tow calculated from its duration and its start and end positions lay outside a range of 3.0 to 6.5 km/hr, its length was recalculated from the survey average towing speed and the tow duration.

Biomass estimation

Each haul's catch was divided by its estimated swept area calculated from wingspread and track length to estimate a biomass density. Unweighted mean stratum densities were multiplied by the stratum area to compute stratum biomass, and a corresponding error variance for the stratum biomass estimate was also calculated for strata with two or more accepted hauls. For strata with only one accepted haul, an error coefficient of variation of 0.95 was assigned. Stratum biomasses and their error variances were summed to get regional and overall estimates.

Indices of distribution and location of shrimp biomass

Indices to summarize how widely the survey biomass is distributed and a measure of its central latitude were calculated (Kingsley 2008). Data from surveys executed in 1994–2020 was used: there was no survey before 1994 in the southernmost areas and before 1991 in Disko Bay or Vaigat, but since 1994 the series has been consistent. Biomass estimates from the annual survey are customarily presented for 7 divisions of the survey area:

- a northern division, formerly stratified as N1–N9, and re-stratified according to depth information (Wieland and Kanneworff 2004) as U1–U3 with depth strata;
- Disko Bay and Vaigat, formerly stratified as D1–D9, re-stratified as I1 and I2 with depth strata;
- Canadian Exclusive Economic Zone, once 2 divisions, now 1;
- subdivisions of the west coast, from the mouth of Disko Bay and adjacent shelf waters to Paamiut;
- an extreme southerly division, comprising Julianehåb Bay and adjacent waters.

These divisions were given southerly ranks: Julianehåb Bay and the adjacent shelf waters were 1; the subdivisions up the coast were given ranks 2, 3 and 4. The small Canadian sub-division was split, half being included with the subdivisions W1 and W2, and the other half included with survey subdivisions W3 and W4. Disko Bay and Vaigat were given rank 5, and the northernmost subdivision of the survey area was ranked 6. The two strata W8–W9 was in 2022 merge to one stratum as W10 as well as a tiny part of W7.

Then a 'lat. index' was calculated as a mean rank for the survey, weighting by estimated total survey biomass. This index summarises how far north a (weighted) center of gravity of the stock biomass lies.

A 'spread index' was calculated as a Simpson diversity index (Simpson 1949) of the distribution of the biomass:

$$SpreadIndex = \left(\frac{\sum_{Subdivisias} Biomass_{Subdiv}}{\sum_{Subdivisias} (Biomass_{Subdiv})^2} \right)^2$$

This index summarizes how widely the survey stock biomass is distributed among survey subdivisions.

Depth distribution of biomass.

The overall depth distribution of the estimated survey biomass was calculated according to available depth information. Up to 2003, such information was only available for the west-coast area and the Canadian EEZ, and the depth distribution of the biomass was analyzed only for those areas. Since 2004, the northern area and the inshore areas in Disko Bay and Vaigat have been sub-stratified depth and the depth analysis extended to those areas.

A single depth index, in meters, was calculated by assuming that the entire survey biomass in any depth stratum was concentrated at the stratum's midpoint depth, except for the deepest stratum: the fishery takes little from water deeper than 520 m, so the central depth for the 400–600 m stratum was set at 460 m.

Sampling, weighting and "area expansion"

The composition of the stock by size and sex is based on a two-stage analysis of lengths and weights. From catch samples, 1000–2000 individual shrimps are both weighed and measured, and these measurement pairs are used to estimate a weight-length relationship. From each catch a sample of about 0.5 to 3 kg was taken and sorted to species. All specimens of Northern shrimp were classified: juveniles and males composed one class, primiparous and multiparous females two others (Allen 1959, McCrary 1971). The oblique carapace length (CL) of each shrimp in the sample was measured to the nearest 0.1 mm. These length measurements are then supplemented with weight estimates based on the fitted weight-length curve. Aggregated, and then averaged over the stations in a stratum, these

observations of sex and measurements of length and their associated estimates of weight are used to estimate the distribution of the stratum biomass between sex and length classes as well as the numbers of shrimps in the stratum in the various sex and length classes.

The descriptions of calculation methods that follow consider only one stratum. Survey totals are got by summing stratum results. 'Length class' can be generalized to include sex or sex-length class. From the catch and swept area at a station, the single-station estimate of stratum biomass is

$$\hat{B}_{ts} = \frac{Strat.Area_t \cdot Catch_{ts}}{Sw.Area_{ts}}$$

These single-station estimates are averaged. An unweighted analysis gives

$$\hat{B}_t = \frac{Strat.Area_t}{K_t} \sum_s \frac{Catch_{ts}}{Sw.Area_{ts}}$$

where t is the stratum and s is the station, of which there are K_t in stratum t . Shrimp density does not vary much within a haul's distance (Kingsley et al. 2002) and so it is statistically preferable to use the unweighted mean estimate of stratum biomass. This is what is done in the West Greenland survey.

If the number of shrimps in class l in the Length Sample, of weight $Samp.Wt_s$, from station s in stratum t is n_{lts} , the corresponding single-station estimate of the number of shrimps in the class in the stratum is

$$\hat{N}_{lts} = Strat.Area_t \frac{n_{lts}}{Samp.Wt_s} \cdot \frac{Catch_{ts}}{Sw.Area_{ts}}$$

The stratum estimate from many stations is:

$$\hat{N}_{lt} = \frac{Strat.Area_t}{K_t} \sum_s \left(\frac{n_{lts}}{Samp.Wt_s} \cdot \frac{Catch_{ts}}{Sw.Area_{ts}} \right)$$

where the divisor K_t , the number of stations, includes those with no catch. The coefficient

$$\frac{Catch_{ts}}{Samp.Wt_s \cdot Sw.Area_{ts}}$$

common to all length (and sex) classes counted in the Length Sample for a station can be called its 'raising factor'. Given these estimates of numbers, and if estimates $w(l)$ of individual weight at length are available, length-class biomass is given by

$$\hat{W}_{lt} = w(l) \frac{Strat.Area_t}{K_t} \sum_s \left(\frac{n_{lts}}{Samp.Wt_s} \cdot \frac{Catch_{ts}}{Sw.Area_{ts}} \right)$$

Provided that for all Length Samples $\sum_l n_{lts} w(l) = Samp.Wt_s$, i.e. the weight of every Length Sample answers exactly to the number and size of the shrimps that compose it, the sum of length-class biomasses equals the stratum total

biomass calculated from catches and swept areas. This is ensured by using, as the weight of the Length Sample, the total weight of the shrimps it comprises, calculated from the weight-length function, instead of using its weighed weight. In effect, the length-measurement data is used only to partition the stock biomass between sex and length classes.

Where catches were, for one reason or another, not sampled for lengths, the mean of the length frequency distributions from the available samples in that stratum, each raised by its catch and swept area, was applied to the entire stratum biomass. If it occurred that there were no length samples from the catches in an entire stratum, the length distribution estimated for the entire survey from data for the strata that did have length samples would be applied to its estimated biomass.

Results from these calculations were subsequently used to construct area-specific length frequency distributions (LFD). LFD results were used to calculate indices of numbers by sex and length, biomass by sex, an index of fishable biomass (comprising shrimps at least 17 mm CPL), and numbers of small pre-recruits ('age 2 shrimps'), which are expected to enter the fishery in coming years.

For data since 2007 the following weight-length relationship has been fitted:

$$w(l) = w_0 + a \cdot (l - l_0)^z$$

with the parameter l_0 constrained to be less than 4.5 mm. A weighted fit was used with constant coefficient of variation about the fitted line.

As there is no reliable method of aging even young shrimps, indices of numbers at age are obtained by modal analysis of length frequencies for juveniles and males, attempting to fit overlapping age-specific normal distributions to the aggregated length distributions.

Modal analysis is carried out using Partial Mix (Kingsley, 2014, MCSKMIX 2014 © Greenland Institute of Natural Resources), implemented in an Excel spread sheet. Partial MIX fits numbers of shrimps at age 2 years and is estimated by decomposing the length distributions, fitting Normally distributed components. To prevent a skewness to the plus age 3 group, analysis was only done on shrimps below or equal to 19 mm CPL. While using this new method in 2014, all age-2 results from 1996 to 2014 was re-calculated. A more comprehensive description of the method is found in Kingsley (2014).

As growth is probably affected by temperature, the survey area is divided into 6 regions, defined from gradients in bottom temperature (Wieland, 2004), and estimated numbers in strata are pooled over regions. Length-frequency histograms are not smoothed before being analyzed. The analyses of sex and length distribution in the stock, and the modal analyses, were re-done in 2014 for data from 1996–2014. To simplify the modal analysis, and because the main objective is to estimate the numbers at age 2, only the numbers for the 'Juveniles and Males' sex class were put through it. For this re-analysis, strata were grouped: U1 to U3, I1 and I2, W1 to W4, W5 and W6, and W7 to W10. Within each group, the estimated stock numbers in each stratum were aggregated over depth substrata, and the stratum aggregate numbers presented to Partial MIX as a haul.

Bottom temperature

Bottom temperature was measured with a *Starmon* sensor mounted on one of the trawl doors. It records at intervals of 30 s with a resolution of 0.01°C. The average temperature for each haul was calculated after retrieval of the sensor. All measurements taken at greater depths than 150 m were used to calculate a mean bottom temperature weighted for the areas of the survey strata between 150 and 600 m depth.

Results and Discussion

Survey conducts and progress.

The survey in 2024 started from Nuuk May 18th. The first cruise occupied 161 shrimp and fish stations and 12 CTD casts from Nuuk north to Disko Bay in 19 days. The second cruise started from Sisimiut June 8th and occupied 165 shrimp and fish stations and 23 CTD casts in 24 days. The last, and third cruise started from Nuuk July the 4th occupied 32 shrimp and fish stations and no CTD cast were sampled at the third trip. At the second cruise sea ice in the Northern areas (U2 and U1), West of Disko (W1) and in the Canadian area C0/SFA1 preventing trawling all planned stations.

From all planned shrimp and fish stations, at the three cruises, by-catch of benthic faunal invertebrates were sorted from each station, identified to the lowest possible taxonomic level, and some species were preserved in 10% buffered formalin solution for later identification, and both projects aim to investigate the long-term effects of trawling on bottom ecosystems. Furthermore, cod tagging was done at 11 stations during cruise 1 and 2.

Of the 58 planned survey strata, 1 strata (the Canadian zone C0-4) had no stations trawled caused by the ice cover. Due to ice coverage this year, only 1 station was fished in stratum W1-4 and W2-4, C0-2 and C0-3. -Furthermore, the Sea Ice preventing full coverage in stratum U1, U2, W1 and C0.

Of all surveyed stations, 22 stations had no catch of *P. borealis* in most strata there were only 1 or 2 stations with zero catch (Stratum W-1, W3-1, W4-1, W4-2, W5-1, W5-4, W6-1, W6-2, W6-3, W7-1, W7-2, W7-3, W7-4, W10-1, W10-3 and W10-4. All stratum U1 – U3, I1 and I2 had catches of *P. borealis* at all stations.

There were no exceptionally large catches, and none exceeded 1 tonnes. Two stations have more than 900 kg both in Vaigat I2-1. There were in total 90 out of 291, where catches were below 1 kg and only at 25 stations had catches above 200 kg, of which 18 were in Disko Bay & Vaigat, 5 in strata W1-W3, and 2 in the U-regions and 1 in W5-1. In the more southerly areas, stratum W6-W10 yielded an average catch of 2.4 kg, and 8 of 25 stations had no catch of *P. borealis*. Length samples were measured from all stations with catches, even very small ones.

2023 Ice situation

Owing to the ice situation, the proportion of stations taken was less in 2023 than usual. Based on observations from past surveys, it was hypothesized that density of shrimps was higher at lower longitude. Simple linear regressions of density of shrimps (kg/km²) as a function of longitude were performed to test this hypothesis. Overall, the result in the table below, revealed that most slopes are negative, indicating that density tend to be lower with increasing longitude, however, this tendency was not significant within all substrata, and to which intend it is significant may differ over a broader time period (Burmeister and Kingsley, 2015).

Strata	n	Slope	b	Adj R ²	t value (slope)	P
U1-1	9	-4369	249318	0.371	-2.03	0.082
U1-2	25	813	-43786	0.062	1.24	0.229
U1-3	13	-96	7115	0.013	-0.38	0.713
U1-4	14	9.88	-406	0.002	0.15	0.886
U2-2	17	-1759	104223	0.076	-1.11	0.286
U2-3	22	-8200	50044	0.237	-2.49	0.022
U2-4	20	-113	6887	0.171	-1.57	0.142
W1-1	11	-5519	335402	0.378	-2.34	0.044
W1-2	36	-625	38691	0.036	-1.09	0.285

W1-3	22	-901	54573	0.072	-1.24	0.229
W1-4	4	-113	6679	0.399	-1.15	0.368
W3-2	41	-6186	355474	0.273	-3.82	0.001
W3-3	7	2620	-147963	0.479	2.14	0.048
W3-4	12	-904	51624	0.606	-3.92	0.003

Owing to the fact, that the proportion of the strata covered (fished) in 2023, is less than normal and the findings of shrimp density decrease with increasing longitude, it was assumed that the lower limit is the density in the ice-free area multiplied by the ice-free area. The upper limit is the density in the ice-free area multiplied by the area of the whole stratum.

In the present survey document, we have estimated the density, biomass, and other stock components as being the lower limit, and only used available measure from each station sampled, i.e. assuming that the ice-free area is representative of the entire area.

As it appears from the Assessment paper (Burmeister and Kingsley, 2015) that density, biomass and fishable biomass were estimated at the lower limit as well as the upper limits. Upper limits were estimated as an average of the past five-year biomass, density and Fishable biomass in those strata with poorly coverage during the 2023 survey. Both approaches (upper and lower limit) were run in the model for the assessment work.

2024 Ice situation

In 2024 sea ice coverage prevented trawling at some stations, not because of an exceptional ice year, but just because the ice hasn't broken at the time when the survey was conducted.

Overall Biomass and Area Distribution.

All strata biomass estimates have been calculated based on the nominal swept area. The biomass estimates (in tons) for the five main regions appears from table 2. Survey biomass decreased in 2011 and the declining trend in survey biomass continued until 2014 and fluctuated with some smaller ups and downs in 2015 and 2016 (Burmeister and Kingsley, 2015a; Burmeister and Kingsley, 2015) (Table 3, Figure 2a and 2b). In the following year from 2017 to 2020 biomass increased to a most recent peak at 378 Kt. No survey was conducted in 2021, but survey biomass had showed a declining trend since 2020 and is in 2024 (225 Kt) 26% less than in 2023 (303 Kt) (Burmeister and Buch, 2023; NIPAG, 2023). In 2023, a substantial part of the offshore survey area north of 66 N was covered by an abnormal spatial distribution of sea ice. The extension of sea ice in Greenland EEZ has this year been above the average from 1981 to 2010 (<https://iceweb1.cis.ec.gc.ca/>). Because of the substantial amount of sea ice, the northern offshore part of the survey area was poorly covered in 2023. As a consequence, the 2023 estimates are assumed to be estimated at their lower limits (see above for further explanation). However, there was no exceptional ice situation in 2024, even if it was not possible to cover the entire area in all strata due to ice coverage. This was just a consequence of the survey beginning earlier than back in time.

The 2024 survey biomass drop to a recent low of 225 Kt and is 67 % of its past 5 yr. and 77% of its past 10 yr. value. The offshore survey biomass (145 Kt) dropped significantly compared to the past years and is at the fifth lowest value in the time series and way below both its past 5 yr. (52%) and past 10 yr. (65%) mean as well as the serial mean (238 Kt). There was no problem with sea ice inshore Disko Bay & Vaigat, where survey biomass increased (80.4 Kt) and is in 2024 above its past 5-yr. mean (133%), as well as its past its past 10-yr mean (115%). Offshore biomass constitutes 64% and Disko Bay & Vaigat 34% of the total survey biomass. In the Canadian area and owing to ice coverage only two stations were fished, the biomass in the area was estimated to 0.2 Kt, and contributes less than 1% of total offshore survey biomass (Table 3).

In offshore survey regions, survey biomass dropped in most regions, except for an increase in W5 compared to 2023 values, but this was based on only one large haul. In the southernmost area W7-W10 comprise less than 1% of the total biomass (Table 3 Figure 2b).

Densities of *P. borealis* in Disko Bay were almost stable from 2010 to 2014. In the succeeding years, densities were continuously declining, except for 2017, to a low level considerably below the serial mean in 2019. This trend stopped in 2020 and has since been increasing to a value above both its past 5 yr., 10 yr. and serial mean. Inshore region (Disko Bay & Vaigat) had higher densities (8.2 t/km²) than the average offshore regions (1.1 t/km²), where density considerably lower than its past means (Figure 3a). Highest densities in offshore regions were found in W1-W2 (West of Disko Bay) and lowest densities were found in the Southern areas W10 (0.05 t/km²) (Table 5). Overall mean density (1.63 t/km²), which has been declining since 2020, is in 2024 below its serial mean (1988–2023; 2.3 t/km²) and way below both its past 5-year and 10-year mean (Fig. 3b).

The spread index, of how widely the survey reflects the stock biomass is distributed, has shown an increase from 2017 to 2018, remain stable in 2019 and 2020, but declined in 2022 indicating that the stock is not as widely distributed as in the most recent years. The north index increased again in 2022 and since remained stable, after a 5 yr. period with declining trends (Figure. 4).

Depth distribution of the shrimp biomass.

During the early and mid-1990s, the depth distribution of the survey biomass was stable, with a significant contribution from the 400–600 m stratum, but most of the biomass found in 300–400 m of water (Fig. 5a, Fig. 5b). The 200–300 m stratum started showing biomass increases as early as the late-1990s, and at that time, the deepest stratum also started its decline—hence the start of the change in the mean-depth index (Fig. 5b). In the subsequent year biomass at 200 – 300 m increased significantly until 2004, so do the 150–200 and 300–400 m strata, however increased later, and less.

The biomass in the deeper stratum, 400 -600 m, has remained stable since 2010, whereas the biomass in the shallow water has fluctuated throughout the entire time series. The proportion of the biomass in the shallow water constitute in general less than 20% of the total shrimp biomass. Some years less than 5% and some years more than 15%, but with no clear trends between years. In 2024, approx. 17% of the biomass was found in shallow water from 150 – 200 m. This is mainly caused by large catches in two hauls in the strata I2-1 in 2024.

In general, since the late 1990s the majority (80%) of the biomass has been found in depths from 200 to 300 m and 300 to 400 m, while little biomass is found to be in deeper waters > 400 m (Fig 5a and Fig 5b).

In 2001–2024 the survey biomass depth index has ranged between 265 and 300 m, with an average near 278 m compared to an average of 329 m in the period from 1988 to 2000 (Fig 5.c). In 2020 and 2022, the depth index was estimated to approx. 256 m, considerably lower compared to the past 20 years (279 m) but drop to 272 m in 2023 and remained fairly stable in 2024 (277 m).

Demography and recruitment

Length-weight relationships

In 2024, 2081 shrimps were individually weighed and measured (Table below). A single weight-length relationship was fitted to all sex classes. The same relationship was retrospectively fitted to data from 2005–2010 to provide a consistent basis for estimating numbers of pre-recruits for those years; we have compared estimated weight at length from the weight-length relationships used in different years. Parameter values estimated in 2024 were little changed from the past years.

Table: *Pandalus borealis* in West Greenland: parameters of a relationship $w(l) = w_0 + a \cdot (l - l_0)^z$ fitted to weight-length data for individual shrimps.

Year	w_0 (g)	coefficient (mg)	a	l_0 (mm)	exponent z	sample	Scatter (%)	c.v.
1988–2000	0	0.669		0	2.960			
2001–02	0	0.483		0	3.058			
2003	0	0.752		0	2.918			
2004	0	0.765		0	2.909			
2005	0.0310	1.726		1.9	2.719	1616	6.79	
2006	0.0577	1.426		1.6	2.761	1907	7.89	
2007	0.7700	1.789		4.5*	2.782	487	6.42	
2008	-0.0329	1.416		0.8	2.750	2147	6.67	
2007–08	-0.1210	0.403		-1.7	3.053	2634	6.88	
2009	0.0182	2.774		2.2	2.589	1768	6.86	
2010	0.1533	8.155		4.5*	2.320	1096	6.66	
2011	0.1299	9.753		4.5*	2.251	2569	6.64	
2012	0.0819	8.928		4.2	2.273	2300	7.31	
2013	0.1264	9.541		4.5*	2.260	2353	6.66	
2014	0.1058	9.554		4.5*	2.271	2371	6.75	
2015	0.0727	4.165		3.1	2.495	1088	6.79	
2016	0.1888	8.655		4.5*	2.302	1125	5.68	
2017	0.0481	2.775		2.7	2.612	3520	7.52	
2018	0.1331	7.392		4.5*	2.3482	9732	7.48	
2019	0.0977	4.820		3.5	2.451	3256	6.92	
2020	-0.0249	2.107		1.7	2.647	2986	6.81	
2022	0.0325	1.944		1.9	2.688	2822	8.98	
2023	0.1136	7.370		4.3	2.345	3897	7.26	
2024	0.0768	5.392		3.6	2.417	2081	8.13	

* L0 must be no greater than 4.5 mm.

The scatter about the fitted weight-length relationship is consistent from year to year. Whereas the scatter in 2016 was lower than most other years, the scatter in 2022 was higher compared to other years.

Table: *Pandalus borealis* in West Greenland: weights at length predicted from fitted weight-length relationships.

Year	10	15	20	25
1988-2000	0.61	2.03	4.75	9.19
2001-2002	0.55	1.91	4.59	9.08
2003	0.62	2.03	4.70	9.02
2004	0.62	2.02	4.66	8.92
2005	0.54	1.91	4.56	8.82
2006	0.57	1.91	4.50	8.67
2007	0.98	2.01	4.44	8.75
2008	0.60	2.06	4.76	9.02
2007-2008	0.61	2.04	4.70	8.96
2009	0.59	2.06	4.82	9.12
2010	0.58	2.06	4.87	9.17
2011	0.58	2.07	4.79	8.86
2012	0.56	2.06	4.80	8.90
2013	0.58	2.07	4.80	8.92
2014	0.56	2.10	4.93	9.21
2015	0.59	2.08	4.90	9.28
2016	0.63	2.13	4.95	9.24
2017	0.55	2.00	4.80	9.27
2018	0.54	1.98	4.75	9.03
2019	0.57	2.00	4.72	8.96
2020	0.56	2.02	4.74	9.02
2021				
2022	0.56	1.96	4.65	8.93
2023	0.54	2.01	4.79	9.06
2024	0.55	1.99	4.71	8.90
Average	0.59	2.02	4.74	9.01

Estimated weights at length have been consistent over years, and there is very little change from 2010–2024. Though 2016 has rather heavy shrimps at the small medium size, 10, 15 and 20 mm but since 2017 weight at the four size groups have been somewhat stable.

The mean weight of both sexes has decreased steadily over the years until 2016 but have been rather stable since with only some annual minor changes (Fig. 8). On average, the mean weight is 26 mg/yr. for females and 22 mg/yr. for males. Factors which might affect the mean weight over years could be due to a progressive reduction in the size at sex change, which would affect the mean size of both sexes.

Recruitment and mean length at age 2

Length-frequency plots—e.g. regions I1 – I2 (Disko Bay & Vaigat) as well as those for offshore regions, is shown in Fig. 10. Higher abundance of smaller shrimp (less than 17 mm CL) has been observed in the survey since 2018 and have recruited each of the subsequent years entered to the next cohort or into the fishable biomass (e.g., individuals larger than 17 mm CL). However, a first insignificant component with mean CPL at 7–8 mm is low in numbers. These shrimps had probably hatched in the spring of the year before. Catches of this first component are small owing to the mesh size used in the survey; even the second component is not fully retained by the survey gear (Wieland, 2002b).

Regional differences in length at age 2 are obvious, the smallest age 2 shrimps were found in the most northern regions whereas the largest were found in the more southern regions (Table 9). In 2019 - 2024, mean length at age 2, varied from 10.2 mm to 12.5 mm carapace length, but in 2024 all age 2 shrimps were within the range of 11.2 mm to 12.5 mm CL. Year-to-year changes in the mean length at age 2 have been related to shifts in bottom temperature and

changes in stock density of shrimp (Wieland, 2005). For the most recent seven years, however, estimates of the mean size at age 2 were consistent (Table 9).

In 1993–1995, estimates of numbers at age-2 were low, particularly in Disko Bay and Vaigat (Table 10, Fig. 11); in 1996, they were high, especially offshore, but dropped again in 1997. After 1997, age-2 numbers increased steadily to peak in 2001, followed by a steady decline to 2005. A series minimum observed in 1995 was reached again in 2007 and 2012.

Since 2013 numbers of age-2 shrimps increased and more than doubled in 2015, considerably above the series mean (Fig. 11). The high level of age-2 shrimps was not maintained, and numbers of age-2 shrimp drop to a low value in 2017. However, the total numbers of age-2 shrimp increased in 2018, and almost doubled its value in 2019, remained relatively stable in 2020 and 2022, but drop to a value almost its mean in 2023 and below in 2024 (Fig.11). The relatively high numbers of age-2 shrimp are only found in the offshore central regions W1-W4. The number of age-2 shrimp increased little in Disko Bay & Vaigat, while the number of age-2 shrimp in Offshore regions dropped to a low value well below the values observed for the past 5 and 10 years. In the southernmost regions W7 to W10 age-2 shrimps have always been very few (Table 2, Fig 11).

Disko Bay and Vaigat, which include only about 7% of the survey area, has back in time contributed from 30% and up to 72% of the total numbers of age 2 shrimps (Table 10). However, over the most recent years numbers of age-2 shrimp have been declining in Disko Bay & Vaigat, increased little but are in 2024 comprising 40% of the total amount of age-2 shrimp (Table 10, Fig 11a). The contribution from offshore regions has historically been lower, but in 2015-2023, except 2016 and 2022, the abundance of age-2 shrimps was considerably higher offshore than in Disko Bay & Vaigat. However, in 2024, age-2 shrimp dropped offshore and is way below its past means (Table 10).

The age-2 index is correlated with the fishable biomass two, three and four years later (Fig. 13a); lags of two to four years in such a correlation might be reasonable considering that the main contribution to the fishable biomass comes from sizes corresponding to ages 4 to 6 years. These relationships are corrected for serial correlation (autocorrelation) if it is found significant, which only was the case for the correlation of age 2 shrimps and the fishable biomass with 2 years lag. The regressions of age-2 numbers and of fishable biomass with a three or four-year lag have strong correlation, which indicate that shrimp enter the fishable biomass as 5- to 6-year-old shrimps.

The number of pre-recruits (14-16.5 mm CL) were high from 1999 to 2005, then followed by a declining to a low value in 2014. This turned to a significant increase of pre-recruits in 2015, which was not seen in 2016. However, the abundance of pre-recruits reaches a relatively high value in 2017, has since varied in numbers and was in 2020 considerably above the average from the past five and ten years. In 2022 numbers of pre-recruits declined to half the value observed in 2020, increased in 2023, followed by a significant decline in 2024 and is now below its serial mean. Numbers of pre-recruits has historically been higher in offshore regions compared to inshore Disko Bay & Vaigat and, more than 60% of the pre-recruits are still found in offshore regions.

Numbers, spawning stock biomass and fishable biomass

Survey and fishable biomass peaked in 2002 to 2006 and since decreased to a very low level in 2014 (Table 3 and Table 8). In the subsequent years, survey as well as fishable biomass, have increased until 2020, dropped in 2022 and has since been below the past 5-year and 10-year mean and of their serial means.

Compared with the length distributions in past years, the proportion of smaller shrimps, those below about 17 mm CPL caught in 2024 survey, were less in the offshore regions compared to the most recent years, and below its serial mean (Fig. 10). The proportion of the largest females above 23 mm CPL are comparable with observations from the past years in offshore regions, and remained comparable with 2023 in Disko Bay & Vaigat (Fig. 10, Table 6 and Table 7).

Spawning stock biomass—i.e. of females—accounted for more than 40% of the total survey biomass from 2010 to 2013, reached its highest level at 48% in 2014 (Table 7). Since 2018, female's biomass constituted between 37 - 40 %

of the total biomass but is in 2024 below the level for its past 5-year mean as well as its serial mean (110 Kt). Female biomass is in 2024 estimated to a value at 98 Kt, and male biomass 128 Kt (Table 6 and Table 7).

Female biomass in offshore regions were low in 2014, increase in the successive years until 2020. Since female biomass have been declining but however is well below its serial mean. In Disko Bay & Vaigat, female biomass has fluctuated with up and downs since 2014 but has since 2023 been increasing to value close to its serial mean.

Numbers of males declined considerably in offshore regions in 2024 and is only little higher in numbers than to Disko Bay and Vaigat. and in total, both in numbers and biomass, below the serial mean (Fig. 10, Table 6 and Table 7).

Bottom temperature

Area weighted bottom temperatures is given in Fig. 6 and Fig. 14. Bottom temperature has been stable at somewhat 3.1°C from 2008 to 2012, but starting a decrease in 2015 (2.98°C) which continuing in 2018 to 2.1 °C. In conclusion the overall bottom temperature has decreased by 1.5°C from 2014 and until 2018, increased again and has since 2022 been at a value around 3°C.

Regionally the bottom temperature in the Northern regions (U1-U3 and I1-I2) were almost stable at approximately 2.8 °C from 2000 and until 2014. This was followed by a continuous decline until 2018 (1.2°C) followed by a steadily increasing trend to 2.8°C from 2022.

In W1-W4 temperature increased to about 3.9 °C in 2014, followed by a continuous decline to 2.3°C and remained at a comparable value in 2018. However, this cooling trend stopped in 2019, and bottom temperature has been increasing over the past two years to a value at 3.3°C in since 2022. In the more southern areas (W5-W6) temperature has been fairly stable over the past years but increased to 4.3 °C in 2024 and this region has in general “warm” bottom temperature. While temperature in the southernmost regions W7-W9, dropped from 4.68°C in 2014 to 3.39 °C in 2018, bottom temperature increased considerably to above 5 °C in 2019, but dropped again in 2020 to 3.7 °C and has since remained at the same value (Fig. 14).

The depth distribution of the shrimp survey biomass appears to have shifted after, and not concurrently with, the temperature shift (Fig. 6 and Fig. 14). Thus, bottom temperature has been declining since 2015 and the depth index of survey biomass remained comparable to observations for the past 17 years.

Conclusions

Stock size

In 2023, there has been an abnormal spatial distribution of sea ice north of 66°N in Greenland EEZ, which prevents trawling of planned stations during the survey. Due to poor coverage in the survey area, it was uncertain if that year’s results of survey- as well as fishable - biomass and densities, reflect the stock trajectory and status.

Also in 2024, there were issues in some of the more northern regions where sea ice prevents trawling at all stations. However, most depth strata were covered, and the data are assumed to give an acceptable indication of biomass in those regions.

In aggregate, the stock has, despite the decline from its high biomass levels in 2003 – 2006, shown no clear trends since 2007. In fact, at short term (13 year), there has been fluctuations in the stock with ups and downs in biomass. The overall survey biomass dropped (26%) compared to 2023 and is in 2024 (225 Kt), 67% of its past 5-yr mean, 77% of its past 10-yr mean and 76% its serial means (276 Kt). Highest biomasses are found in the more northern regions (U1-U3) and (W1-2), which constitutes 79% of the offshore biomass. The offshore regions are in 2024 constituting 60% of the total surveyed biomass, and 40% of the biomass is situated in Disko Bay & Vaigat.

The offshore and inshore components have had very different trajectories since 2008. Inshore, in Disko Bay and Vaigat, the biomass almost doubled from 2008 to 2010 and was then gradually decreasing to a low level in 2019. In the same period, the offshore biomass has fluctuated with ups and downs. Recruitment patterns have, to some extent, shown minor different trajectories, however not so conspicuously as for the survey biomass.

Fishable biomass of survey has decreased since 2020. In 2024 this decline is mainly caused by a decrease of the fishable biomass in offshore regions, whereas fishable biomass increased in Disko Bay & Vaigat. In offshore regions fishable biomass is way below its past 5-yr. and 10-yr. means but above in Disko Bay & Vaigat. Total, fishable biomass is below its serial mean (210 kt), as well as both its past 5-year mean and 10-year mean. In 2024 fishable biomass constitute 87% of the total surveyed biomass.

Stock distribution

The area over which the stock is distributed has increased from 2013 – 2020 and dropped little in 2022, but remains concentrated in Disko Bay, Vaigat and the Northern part of its range (north of 66°N). Densities are more than seven times higher in Disko Bay and Vaigat compared to offshore regions. Densities in offshore regions are well below its past means, while in Disko Bay & Vaigat both its past 5-yr and 10-yr. means. The northernmost regions (U areas) and West of Disko Bay (W1-2) in the offshore regions, showed highest densities in 2024 but at values lower than observed for the past 10 years. Densities are practically zero on in the southernmost regions.

The latitude index of the survey has declined from 2010 – 2013, followed by a continuous increase until 2018, remained almost unchanged in 2019 and 2020, but dropped in 2022 and have since been at a comparable level. The North index remain stable from 2009 to 2015 owing to high proportion of biomass in the Northern regions and in Disko Bay & Vaigat, and lower proportion of biomass in the W- regions. After 3 years of a declining trend in the North index, the value for the past years has been comparable to the period before the decline. Survey biomass from the northern (above 66°N) and Disko Bay & Vaigat regions constitute in 2024 almost 93% of the total survey biomass.

Since the late 1990s, the stock appears to be found in shallower water than before. Nevertheless, the proportion of the biomass in the shallow water (100-200 m) constitutes in general less than 20% of the total shrimp biomass. However, in 2020 and 2022 more biomass (approx. 30%) were found in shallow waters mainly caused by two catches in that depth strata. Since the late 1990s the majority (80%) of the biomass has been found in depths from 200 to 300 m and 300 to 400 m, while little biomass is found to be at deeper waters > 400 m.

Survey biomass depth index has ranged between 265 and 300 m since 2001, with an average near 281.5 m compared to an average of 329 m in the period from 1988 to 2000 (Fig 5.c). In 2020 and 2022 the depth index was estimated to approx. 255 m but was 277 m in 2024 and comparable with the past 5 year (265 m).

Stock composition

By numbers and biomass, the stock is in 2024 weighted toward males, but the females still composed a high proportion of the total fishable (46%) and surveyed biomass (approx. 43%). Fishable biomass is below at the average for the serial mean and as a proportion of the total survey biomass and compose to a relatively high degree of males.

Both numbers at age-2 shrimp and the numbers of pre-recruits (14-16,5 mm CL) in total are below the serial mean and its most resents averages. Values of age-2 shrimp, and pre-recruits are in offshore regions more than two times higher than those of Disko Bay & Vaigat.

Acknowledgements

Thanks to all the crew members at the research vessel Tarajoq, cruise leaders, technicians as well as students for their effort during the annual shrimp and fish survey. All their work in labs as well as in the factory is essential for achieve

useful measures of fish and shrimps, which is the foundation for data analysis in this document. Thank to Karl Zinglersen, Greenland Institute of Natural Resources, Dep. Environment, and mineral Resources, for preparation of map (Fig. 1).



References

- ALLEN, J.A. 1959. On the biology of *Pandalus borealis* Kroger, with reference to a population off the Northumberland coast. *J. Mar. Biol. Assoc. U.K.*, **38**: 189-220.
- AITCHISON, J. 1955. On the distribution of a positive random variable having a discrete probability mass at the origin. *J. Am. Stat. Assoc.* 50: 901-908
- BURMEISTER, AD. AND BUCH, T.T. 2023. The west Greenland trawl survey for *Pandalus borealis*, 2023, with reference to earlier results. *NAFO SCR Doc.*, No. 23/045, Serial No. N7443.
- BURMEISTER, AD. AND RÍGET, F.F. 2022. The west Greenland trawl survey for *Pandalus borealis*, 2022, with reference to earlier results. *NAFO SCR Doc.*, No. 22/045, Serial No. N7326.
- BURMEISTER, AD. AND KINGSLEY, M.C.S. 2015. The west Greenland trawl survey for *Pandalus borealis*, 2015, with reference to earlier results. *NAFO SCR Doc.*, No. 15/043, Serial No. N6478.
- BURMEISTER, AD. AND KINGSLEY, M.C.S. 2015. A provisional Assessment of the Shrimp Stock off West Greenland in 2015. *NAFO SCR Doc.*, No. 15/044, Serial No. N6479.
- CARLSSON, D.M. and P. KANNEWORFF. 2000. Stratified-random trawl survey for shrimp (*Pandalus borealis*) in NAFO Sub area 0+1, in 2000. *NAFO SCR Doc.*, No. 78, Serial No. N4335.
- CARLSSON, D., O. FOLMER, P. KANNEWORFF, M.C.S. KINGSLEY and M. PENNINGTON. 2000. Improving the West Greenland Trawl Survey for shrimp (*Pandalus borealis*). *J. North. Atl. Fish. Sci.*, **27**: 151-160.
- KINGSLEY, M.C.S. 2014. Numbers of Age-2 Shrimps in West Greenland—again. *NAFO SCR Doc.*, No. 14/058, Serial No. N6360.
- KINGSLEY, M.C.S. 2001a. Effects in 2001 of recent modifications to the design of the West Greenland Shrimp Survey. *NAFO SCR Doc.*, No. 176, Serial No. N4565.
- KINGSLEY, M.C.S. 2001b. Studies in 2001 on the end effect of the Skjervøy 3000 trawl in the West Greenland shrimp survey. *NAFO SCR Doc.*, No. 177, Serial No. N4566.
- KINGSLEY, M.C.S., P. KANNEWORFF and D.M. CARLSSON. 1999. Modifications to the design of the trawl survey for *Pandalus borealis* in West Greenland waters: effects on bias and precision. *NAFO SCR Doc.*, No. 105, Serial No. N4184.
- KINGSLEY, M.C.S., D.M. CARLSSON, P. KANNEWORFF and M. PENNINGTON. 2002. Spatial structure of the resource of *Pandalus borealis* and some implications for trawl survey. *Fish. Res.* **58**: 171-183.
- KINGSLEY, M.C.S., P. KANNEWORFF and D.M. CARLSSON. 2004. Buffered random sampling: a sequential inhibited spatial point process applied to sampling in a trawl survey for Northern shrimp *Pandalus borealis* in West Greenland waters. *ICES J. Mar. Sci.*, **61**: 12-24.
- KINGSLEY, M.C.S. 2008. Indices of distribution and location of shrimp biomass for the West Greenland research trawl survey. *NAFO SCR Doc.*, No 78, Serial No. N5610.
- MCCRARY, J.A. 1971. Sternal spines as a characteristic for differentiating between females of some Pandalidae. *J. Fish. Res. Board Can.*, **28**: 98-100.
- NAFO/ICES 2015. NAFO/ICES *Pandalus* Assessment Group Meeting, 9-16 September 2015, Northwest Atlantic Fisheries Centre, St. John's, Newfoundland, Canada. *NAFO SCS Doc.* 15/13 Serial No. N6497, ICES CM 2015/ACOM:14
- PENNINGTON, M. 1983. Efficient estimators of abundance for fish and plankton surveys. *Biometrics* 39: 281-286
- WIELAND, K. 2002a. A new length-weight relationship for Northern shrimp (*Pandalus borealis*) off West Greenland (NAFO Subareas 0+1). *NAFO SCR Doc.*, No. 144, Serial No. N4773.

- WIELAND, K. 2002b. The use of fine-meshed bags for sampling juvenile Northern shrimp (*Pandalus borealis*) in the West Greenland Bottom Trawl Survey. *NAFO SCR Doc.*, No. 145, Serial No. N4774.
- WIELAND, K. 2004. Abundance, mean size at age and growth of Northern shrimp (*Pandalus borealis*) juveniles and males off West Greenland in 1993–2004. *NAFO SCR Doc.*, No. 04/73, Serial No. N5043.
- WIELAND, K. 2005. Changes in recruitment, growth and stock size of Northern shrimp (*Pandalus borealis*) at West Greenland: temperature and density-dependent effects at released predation pressure. *ICES J. Mar. Sci.* **62**: 1454-1462.
- WIELAND, K. and D.M. CARLSSON. 2001. Geographical distribution and mean size of different life stages of Northern shrimp (*Pandalus borealis*) off West Greenland. *NAFO SCR Doc.*, No. 01/178, Serial No. N4567.
- WIELAND, K. and P. KANNEWORFF. 2004. Revision of depth contours and stratification of the West Greenland Bottom Trawl Survey for Northern shrimp. Technical report No. 56, Greenland Institute of Natural Resources (http://www.natur.gl/publikationer/tekniske_rapporter).
- WIELAND, K. and M. STORR-PAULSEN. 2006. Effect of tow duration on catch rates and mean length of Northern shrimp (*Pandalus borealis*) and Greenland halibut (*Reinhardtius hippoglossoides*) in the West Greenland Bottom Trawl Survey. *Fish. Res.* **78**: 276-285.

Table 1. *Pandalus borealis* in West Greenland: vessels, trawl types and rigging parameters used in the West Greenland Bottom Trawl Survey for shrimp and fish, 1988–2024.

	Vessel	Trawl	Bridle length (m)	Wing-spread (m)	
1988	Elias Kleist	Skjervøy	59.9	23.1	*
1989	Sisimiut	“	81.1	17.9	*
1990	Maniitsoq	“	59.9	23.1	*
1991	Paamiut	“	75.1	28.3	**
1992–2003	“	“	60.1	20.1–25.2	**
2004	“	“	54.0	25.7	**
2005–2017	“	Cosmos	54.0	27.4–29.3	**
2018	Sjurdarberg	Cosmos	54.0	30.2	**
2019	Helga Maria	Cosmos	54.0	31.3	**
2020	Helga Maria	Cosmos	54.0	32.6	**
2022	Tarajoq	Cosmos	54.0	30.0	**
2023	Tarajoq	Cosmos	54.0	28.8	**
2024	Tarajoq	Cosmos	54.0	29.2	**

(*: from tank experiments (Per Kannevorff, pers.com.), **: average for all valid tows calculated from measures of door spread and approximate geometry of the trawl).

Table 2. *Pandalus borealis* in West Greenland: survey estimates of total biomass 2024.

Stratum	Area (km ²)	Stations	Biomass density (t/km ²)	Biomass (Kt)	Biomass error variance	Error coefft of variation (%)
C0-2	1125	1	0.073	0.082	0.0061	95.0
C0-3	2317	1	0.047	0.109	0.0107	95.0
C0-4	933	0	0.000	0.000	0.0000	0.0
Overall C0	4375	2	0.044	0.191	0.0168	67.8
I1-1	534	2	12.336	6.588	3.8167	29.7
I1-2	2030	8	9.295	18.870	9.0475	15.9
I1-3	2307	7	13.289	30.657	190.1452	45.0
I1-4	1424	4	1.311	1.866	0.0203	7.6
I2-1	448	3	25.300	11.334	10.8779	29.1
I2-2	769	3	9.686	7.449	0.1921	5.9
I2-3	885	3	2.805	2.482	0.7848	35.7
I2-4	1383	3	0.812	1.122	0.0069	7.4
Overall I	9780	33	8.218	80.368	214.8914	18.2
U1-1	2138	3	0.672	1.438	0.1102	23.1
U1-2	5093	7	2.690	13.699	34.5372	42.9
U1-3	5333	2	0.868	4.631	10.0594	68.5
U1-4	4947	2	0.329	1.627	0.6790	50.6
U2-2	6664	11	1.837	12.241	8.1813	23.4
U2-3	8849	3	1.303	11.530	35.6297	51.8
U2-4	8019	3	0.249	1.996	1.3882	59.0
U3-1	2252	2	0.663	1.492	0.1436	25.4
U3-2	3036	6	4.422	13.424	10.1510	23.7
U3-3	2130	5	1.363	2.902	0.4180	22.3
U3-4	2794	3	0.260	0.726	0.0256	22.0
Overall U	51255	47	1.282	65.708	101.3235	15.3
W1-1	2858	7	1.953	5.581	2.5224	28.5
W1-2	6239	14	2.567	16.014	11.9875	21.6
W1-3	7454	11	1.075	8.013	4.6678	27.0
W1-4	892	1	0.000	0.000	0.0000	0.0
W2-1	2170	3	0.960	2.083	0.3047	26.5
W2-2	3030	8	5.067	15.354	14.6109	24.9
W2-3	1728	5	0.309	0.533	0.0105	19.2
W2-4	962	1	0.647	0.622	0.3491	95.0
W3-1	1955	6	1.462	2.858	1.6917	45.5
W3-2	4817	12	1.091	5.254	14.1159	71.5
W3-3	2107	6	0.307	0.647	0.0196	21.6
W3-4	3185	6	1.411	4.495	1.8707	30.4
W4-1	4336	12	0.244	1.057	0.6974	79.0
W4-2	1940	22	0.769	1.492	0.2355	32.5
W4-3	871	11	0.082	0.071	0.0019	61.3
W4-4	1871	3	0.015	0.029	0.0004	73.1
W5-1	2708	8	1.780	4.819	23.0978	99.7
W5-2	4103	8	1.549	6.354	22.5423	74.7
W5-3	1960	4	0.077	0.150	0.0187	91.0
W5-4	2774	5	0.033	0.092	0.0072	91.6
W6-1	1481	9	0.671	0.994	0.2379	49.1
W6-2	1976	11	0.199	0.393	0.0393	50.4
W6-3	1475	7	0.488	0.720	0.3246	79.1
W6-4	944	4	0.009	0.008	0.0001	97.6
W7-1	1935	3	0.001	0.002	0.0000	50.3
W7-2	671	5	0.011	0.007	0.0000	46.5
W7-3	179	3	0.001	0.000	0.0000	42.6
W7-4	184	4	0.001	0.000	0.0000	71.7
W10-1	2821	3	0.000	0.001	0.0000	100.0
W10-2	1768	3	0.270	0.477	0.2269	99.8
W10-3	1127	2	0.505	0.569	0.3234	100.0
W10-4	1436	2	0.012	0.017	0.0003	100.0
Overall W	73957	209	1.064	78.709	99.9044	12.7
Survey totals	139367	291	1.614	224.976	416.1360	9.1

† strata with 1 trawled station have been assigned an error coefficient of variation of 95%* Substrata C0 and U1-U2, W1 were not fully covered due to Ice cover.

Table 3. *Pandalus borealis* in West Greenland: biomass estimates (Kt) for survey subdivisions and standard errors for the entire survey in 1988–2024.

Year	NI-9/ U1-3 ^{1,5}	C1-3/C0 ^{1,6}	W1-2	W3-4	W5-7 ²	S/W8-9 ¹	D1-9/II-2 ^{3,1}	Total	SE ⁴
1988	22.6	9.5	55.1	85.5	17.7		39.2	229.7	24.7
1989	11.1	3.7	50.0	82.7	39.0		39.2	225.7	32.3
1990	11.0	9.1	78.6	53.9	23.5		39.2	215.3	32.6
1991	5.1	4.2	26.8	47.4	23.3		43.1	149.9	23.0
1992	18.1	22.2	46.2	30.6	45.8		41.4	204.4	32.5
1993	6.9	2.9	93.8	36.7	62.2		28.3	230.8	30.9
1994	6.6	6.0	95.0	44.5	32.6	16.7	34.0	235.4	51.7
1995	6.8	3.9	39.0	52.4	48.7	1.6	39.1	191.4	30.6
1996	8.8	1.5	46.4	31.5	80.0	3.3	44.3	215.9	40.4
1997	5.7	0.2	34.7	13.1	57.9	21.8	44.3	177.7	31.1
1998	7.0	0.4	37.8	100.6	45.1	18.6	51.8	261.2	57.6
1999	17.6	10.5	50.1	23.2	50.5	56.0	52.6	260.6	42.1
2000	8.4	10.7	62.1	69.8	71.0	21.8	73.0	316.9	40.3
2001	34.1	3.7	74.3	47.6	58.5	36.3	72.1	326.7	44.2
2002	17.4	5.4	114.0	62.1	94.9	40.5	85.8	420.2	60.0
2003	109.3	5.9	148.6	93.3	98.0	35.0	107.7	597.8	77.0
2004	111.2	3.5	152.8	96.5	102.6	15.4	81.4	563.4	103.7
2005	100.5	9.3	159.9	87.2	53.4	1.9	139.6	551.9	88.4
2006	54.7	45.8	108.9	60.6	92.2	12.5	110.7	484.0	65.1
2007	61.2	1.7	128.1	64.0	21.3	1.2	79.1	356.6	44.3
2008	91.7	16.7	61.3	40.0	20.9	0.7	50.8	282.1	28.3
2009	91.7	4.3	62.9	30.1	18.4	1.0	70.1	278.4	27.1
2010	73.1	3.0	89.6	65.3	13.5	0.9	99.3	344.7	44.6
2011	55.5	⁽¹⁾	69.2	6.1	34.3	2.6	92.9	260.6	36.1
2012	33.5	⁽¹⁾	33.8	7.0	23.1	0.4	92.5	190.3	20.6
2013	54.1	0.4	51.6	37.4	8.6	0.2	81.4	233.8	23.2
2014	29.4	⁽¹⁾	34.5	12.1	10.4	0.0	93.5	179.9	16.6
2015	75.4	⁽¹⁾	51.5	59.9	18.0	0.6	78.2	283.6	41.7
2016	60.5	⁽¹⁾	48.0	25.5	10.3	2.8	64.8	212.0	19.1
2017	69.8	3.1	72.7	60.0	29.6	0.0	80.8	316.2	29.1
2018	65.8	⁽¹⁾	67.8	41.9	44.4	0.0	72.2	292.1	29.5
2019	65.1	⁽¹⁾	98.1	45.6	80.2	0.0	44.9	334.0	46.3
2020	89.0	⁽¹⁾	87.7	56.3	77.7	0.3	67.3	378.3	66.2
2021									
2022	104.1	⁽¹⁾	101.0	46.2	27.6	0.3	55.4	334.7	44.3
2023	80.4	⁽¹⁾	74.9	34.7	38.5	0.2	73.7	302.5	37.2
2024	65.7	0.2	48.2	15.9	13.5	1.1	80.4	225.0	19.3
Mean 1988-2024	48.0	7.2	73.7	49.1	44.1	9.8	67.9	296.2	41.2

1: New stratification introduced in 2003 (regions N and S) and in 2004 (regions U, C and D)

2: Areas W6 and W7 were sampled from 1990 and 1993, respectively

3: D1-D9 1988-90 not sampled but set to mean of 1991-1997.

4: Standard error calculated excluding D1-D9 in 1988-1990

5: Probably underestimated due to poor coverage of the northern part of the area N

6: Canada(C) in 2011, 2012 and 2014, 2015, 2016, 2018, 2020, 2022 and 2023 was not sampled due to ice condition.

7) Substrata in U1-U2, W1-2, W1-3, W1-4, W3-2, W3-3 and W3-4 were not covered in 2023 due to Ice cover.

Table 4. *Pandalus borealis* in West Greenland: error coefficients of variation (%) for the biomass estimates of five main survey regions and the entire survey area in 1988–2020. (1) Canada(C) in 2011, 2012 and 2014, 2015, 2016, 2018, 2020 - 2024 was not sampled due to ice condition or other priorities.

Year	N1-9/ U1-3	C1-3/C0	W1-2	W3-4	W5-7	S/W8-9/W10	D1-9/I1-2	Total survey	Number of hauls
1988	31.4	40.0	17.9	26.4	42.5	-	-	14.41	131
1989	22.2	42.8	23.9	33.2	35.0	-	-	18.60	130
1990	43.5	39.9	22.7	39.5	42.0	-	-	18.30	109
1991	40.2	27.1	21.2	30.4	30.6	-	22.9	13.37	194
1992	16.9	68.9	15.5	17.9	42.0	-	15.7	13.84	167
1993	51.6	53.3	14.6	28.0	28.5	-	19.4	11.66	157
1994	48.7	18.3	27.2	16.8	45.9	99.2	26.0	19.11	157
1995	47.1	44.7	20.0	22.6	36.3	74.0	17.7	13.93	163
1996	52.6	91.0	23.9	19.8	36.2	95.0	10.6	16.31	148
1997	37.9	61.9	15.8	20.2	43.1	14.6	14.5	15.26	167
1998	40.4	44.0	33.2	44.5	30.6	58.8	18.4	19.19	209
1999	51.1	80.0	13.1	14.8	27.7	52.1	14.2	14.08	227
2000	36.1	7.8	21.5	32.7	18.5	56.8	12.9	11.08	198
2001	26.5	44.5	24.9	45.0	25.6	22.8	18.6	11.77	224
2002	56.0	45.4	16.0	28.9	36.5	55.0	18.7	12.44	216
2003	26.8	44.4	17.5	16.0	34.9	49.9	17.5	11.21	172
2004	24.9	22.6	22.8	27.1	24.1	71.4	11.6	16.03	187
2005	17.4	97.3	22.8	38.0	50.4	48.7	34.6	16.02	194
2006	20.5	79.0	19.2	20.5	41.3	79.4	12.9	13.41	223
2007	21.9	45.1	19.8	32.6	8.8	56.8	20.8	12.43	223
2008	17.3	80.7	15.6	33.1	43.5	44.8	11.5	10.02	204
2009	22.1	59.6	12.8	18.7	39.0	53.0	15.9	9.72	247
2010	11.1	29.7	27.0	61.0	66.9	98.7	10.0	12.94	270
2011	9.8	-(1)	19.1	26.2	89.0	80.5	12.4	13.85	192
2012	16.0	-(1)	12.4	23.9	45.8	84.6	17.4	10.83	193
2013	16.1	76.8	21.1	41.8	55.6	78.6	11.6	9.93	181
2014	26.8	-(1)	19.6	43.2	34.7	65.0	11.6	9.23	189
2015	20.3	-(1)	33.2	58.3	45.5	51.8	10.7	14.69	186
2016	12.0	-(1)	15.7	31.6	54.2	99.9	18.4	9.03	156
2017	12.4	74.2	16.2	31.0	46.3	53.8	13.2	9.20	215
2018	16.1	-(1)	14.7	27.4	47.3	63.3	10.8	10.11	184
2019	15.2	-(1)	21.2	42.6	41.4	86.1	7.7	13.86	166
2020	24.0	-(1)	14.7	27.4	47.3	63.3	10.8	17.49	187
2021									
2022	24.0	-(1)	51.4	80.5	39.4	86.8	8.3	13.25	206
2023	15.4	-(1)	7.9	17.3	72.1	83.3	10.8	12.29	213
2024	11.4	53.5	39.7	27.1	50.2	69.8	18.2	8.56	291
Mean 1994-2022	25.9	55.0	21.3	32.4	42.6	66.6	14.9	12.9	199.6

Table 5. *Pandalus borealis* in West Greenland: estimated mean densities (t/km²) for survey subdivisions in 1988–2024.

Year	N1-9/ U1-3	C1-3/C0	W1-2	W3-4	W5-7	S/W8- 9/10	D1- 9/11-2
1988	0.54	2.77	2.34	3.94	1.76	-	-
1989	0.25	1.08	2.76	3.81	3.88	-	-
1990	0.25	2.65	3.33	2.48	1.59	-	-
1991	0.12	1.23	1.14	2.18	1.57	-	4.60
1992	0.44	6.46	1.96	1.41	3.09	-	4.42
1993	0.17	0.85	3.55	1.68	3.32	-	3.02
1994	0.17	1.76	3.59	2.03	1.74	3.22	3.63
1995	0.18	1.15	1.47	2.39	2.60	0.24	4.17
1996	0.23	0.44	1.75	1.44	4.27	0.51	4.73
1997	0.15	0.06	1.31	0.60	3.09	3.35	4.73
1998	0.18	0.11	1.43	4.59	2.41	2.85	5.54
1999	0.46	3.06	1.89	1.10	2.70	8.59	5.62
2000	0.22	3.10	2.35	3.18	3.79	3.35	7.80
2001	0.89	1.08	2.81	2.17	3.12	5.57	7.70
2002	0.45	1.57	4.31	4.46	5.07	6.21	9.16
2003	2.22	1.39	6.11	6.25	5.23	5.80	11.49
2004	2.20	0.82	6.25	4.71	4.76	2.65	8.37
2005	1.99	2.20	6.54	4.25	2.48	0.34	14.19
2006	1.08	10.81	4.46	2.96	4.28	2.20	11.26
2007	1.21	0.40	5.24	3.12	0.99	0.21	8.04
2008	1.85	3.94	2.53	1.94	0.97	0.13	5.09
2009	1.85	1.01	2.59	1.46	0.85	0.17	7.03
2010	1.47	0.70	3.70	3.16	0.63	0.16	9.96
2011	1.12	-	2.95	0.30	1.59	0.46	9.32
2012	0.67	-	1.40	0.34	1.07	0.07	9.28
2013	1.09	0.13	2.13	1.81	0.40	0.05	8.16
2014	0.59	0.00	1.42	0.59	0.48	0.00	9.38
2015	1.52	-	2.12	2.90	0.84	0.10	7.85
2016	1.22	-	1.98	1.24	0.48	0.49	6.50
2017	1.41	0.99	3.10	2.91	1.37	0.01	8.11
2018	1.33	-	2.89	2.03	2.06	0.01	7.25
2019	1.31	-	4.05	2.21	3.72	0.01	4.51
2020	1.79	-	3.62	2.73	3.60	0.06	6.75
2021							
2022	2.03	-	4.13	2.19	1.35	0.05	5.67
2023	1.57	-	2.97	1.65	1.89	0.03	7.54
2024	1.28	0.00	1.91	0.75	0.66	0.15	8.22
Serial mean	0.99	1.84	3.00	2.42	2.32	1.57	7.24

Table 6. *Pandalus borealis* in West Greenland: estimated numbers (billions) by sex

Year	Males	Females	Total	Males %	Females %
1988 ¹	26.8	9.3	36.1	74.3	25.7
1989 ¹	39.0	6.9	45.9	85.0	15.0
1990 ¹	29.3	8.9	38.1	76.8	23.2
1991	19.6	5.1	24.7	79.3	20.7
1992	29.4	6.5	35.9	81.9	18.1
1993	34.8	8.3	43.1	80.7	19.3
1994	32.0	8.9	40.9	78.3	21.7
1995	27.7	6.5	34.2	80.9	19.1
1996	38.2	6.6	44.8	85.2	14.8
1997	27.2	6.3	33.5	81.2	18.8
1998	41.0	9.9	50.9	80.5	19.5
1999	42.5	9.9	52.3	81.1	18.9
2000	62.4	11.1	73.4	84.9	15.1
2001	56.6	11.8	68.4	82.7	17.3
2002	85.3	14.9	100.1	85.1	14.9
2003	99.4	24.9	124.4	80.0	20.0
2004	89.4	26.3	115.8	77.3	22.7
2005	94.5	25.1	119.6	79.0	21.0
2006	78.3	24.6	102.9	76.1	23.9
2007	55.1	16.0	71.1	77.4	22.6
2008	42.4	11.8	54.2	78.2	21.8
2009	41.3	12.0	53.3	77.4	22.6
2010	52.9	13.5	66.3	79.7	20.3
2011 ²	36.8	13.0	49.8	74.0	26.0
2012 ²	28.8	8.7	37.4	77.0	23.2
2013	31.1	12.0	43.1	72.2	27.8
2014	22.8	9.2	32	71.3	28.8
2015	51.3	10.6	61.9	82.9	17.1
2016	27.6	10.5	38.1	72.4	27.6
2017	47.7	14.2	61.9	77.1	22.9
2018	44.3	12.6	56.9	77.9	22.1
2019	53.2	14.2	67.4	78.9	21.1
2020	65.2	15.4	80.6	80.9	19.1
2021					
2022	55.5	14.4	69.9	79.4	20.6
2023	45.4	12.2	57.5	79.0	21.2
2024	31.5	10.7	34.1	92.4	31.4
Average	46.8	12.3	58.9	79.4	21.3

¹ mean values for Disko Bay and Vaigat in 1991–1997 have been inserted for 1988–1990, and included in the calculation of the average.

² area C0 was not surveyed in 2011, 2012, 2014 – 2016, 2018, 2020 and 2022 owing to sea ice; and in 2014 due to time trouble; no correction has been made.

³ Substrata W1-4 in 2011, 2015, 2017 and 2018, W9-4 in 2015 and W9-4 were not surveyed due to trawl difficulties and poor bottom conditions.

Table 7. *Pandalus borealis* in West Greenland: biomass estimates ('000 t) by sex based on length-weight distributions from the West Greenland shrimp survey in 1988–2024. 1991–1997 mean values for Disko Bay and Vaigat have been used for 1988–1990 and included in the calculation of the average data for 2005–2010 was re-analyzed in 2011.

Year	Males	Females	Total	Males %	Females %
1988	134.7	94.8	229.5	58.7	41.3
1989	157.1	68.6	225.7	69.6	30.4
1990	129.4	85.4	214.9	60.2	39.8
1991	100.5	49.4	149.9	67.0	33.0
1992	141.3	63.1	204.4	69.1	30.9
1993	149.2	81.9	231.1	64.6	35.4
1994	146.5	88.9	235.4	62.2	37.8
1995	124.5	66.9	191.4	65.0	35.0
1996	147.9	68.0	215.9	68.5	31.5
1997	114.7	62.9	177.7	64.6	35.4
1998	170.4	90.9	261.3	65.2	34.8
1999	166.7	93.9	260.6	64.0	36.0
2000	213.8	100.2	314.0	68.1	31.9
2001	199.1	108.3	307.4	64.8	35.2
2002	293.6	126.6	420.2	69.9	30.1
2003	389.2	208.6	597.8	65.1	34.9
2004	353.1	210.3	563.4	62.7	37.3
2005	355.2	196.7	551.9	64.4	35.6
2006	297.4	188.0	485.4	61.3	38.7
2007	227.8	128.7	356.6	63.9	36.1
2008	182.6	99.5	282.1	64.7	35.3
2009	173.5	105.0	278.4	62.3	37.7
2010	222.3	122.4	344.7	64.5	35.5
2011	148.5	112.0	260.6	57.0	43.0
2012	115.4	74.9	190.3	60.7	39.3
2013	129.9	103.9	233.8	55.6	44.4
2014	93.8	86.0	179.8	52.2	47.8
2015	184.6	99.0	283.6	65.1	34.9
2016	113.6	98.4	212.0	53.6	46.4
2017	181.1	135.1	316.2	57.3	42.7
2018	175.8	116.3	292.1	60.2	39.8
2019	204.3	129.7	334	61.2	38.8
2020	237.1	141.2	378.3	62.7	37.3
2021					
2022	204.9	129.7	334.7	61.2	38.8
2023	162.8	111.9	274.7	59.3	40.7
2024	127.8	97.2	225	56.8	43.2
Average	185.3	109.6	294.9	62.6	37.4

Table 8. *Pandalus borealis* in West Greenland: estimates of fishable biomass (≥ 17 mm CL; '000 t) from the West Greenland shrimp survey in 1988–2024.

Year	Offshore fishable		Disko fishable		Overall fishable	
	biomass	%	biomass	%	biomass	%
1988	186.2		37.0		223.2	
1989	171.9		37.0		209.0	
1990	170.0		37.0		207.0	
1991	104.7	98%	41.3	96%	146.0	97%
1992	154.8	95%	39.4	95%	194.2	95%
1993	189.4	94%	27.1	96%	216.5	94%
1994	191.0	95%	32.1	94%	223.1	95%
1995	144.9	95%	38.3	98%	183.2	96%
1996	150.6	88%	41.5	94%	192.1	89%
1997	127.7	96%	39.4	89%	167.1	94%
1998	197.2	94%	47.1	91%	244.3	94%
1999	195.0	94%	42.3	80%	237.3	91%
2000	219.8	90%	60.6	83%	280.3	88%
2001	216.8	85%	63.7	88%	280.5	86%
2002	302.2	90%	67.2	78%	369.5	88%
2003	454.0	93%	94.3	88%	548.3	92%
2004	457.5	95%	70.8	87%	528.3	94%
2005	381.8	93%	112.3	80%	494.2	90%
2006	358.6	96%	92.4	83%	451.0	93%
2007	264.7	95%	71.3	90%	336.1	94%
2008	216.8	94%	45.8	90%	262.6	93%
2009	192.2	92%	62.8	90%	255.1	92%
2010	229.8	94%	88.9	90%	318.7	92%
2011	155.9	93%	83.1	89%	239.0	92%
2012	89.5	91%	83.9	91%	173.3	91%
2013	143.6	94%	74.6	92%	218.1	93%
2014	81.7	95%	85.5	91%	167.2	93%
2015	178.8	87%	69.3	89%	248.1	87%
2016	137.3	70%	58.3	90%	195.6	92%
2017	207.5	88%	73.8	91%	281.3	89%
2018	204.1	93%	66.4	92%	270.5	93%
2019	260.8	90%	41.2	92%	302.0	90%
2020	264.4	85%	65.0	97%	329.4	87%
2021						
2022	256	92%	48.1	87%	304.2	91%
2023	170.6	77%	65.5	89%	235.4	81%
2024	136.6	61%	74.6	92%	211.2	146%
Average	210.1	91%	62	90%	271	91%

¹ 1991–1997 mean values for Disko Bay and Vaigat have been used for 1988–1990, and included in the calculation of the average.

² data for 2005–2010 was re-analysed in 2011.

³ area C0 was not surveyed in 2011–2016, 2018, 2020–2024, except 2013 nor substratum W1–4 in 2011 and 2015, owing to sea ice; and W9–4 in 2015 and W2–4 due to trawl difficulties. Furthermore W8–2 and W9–4 were fished due to lack of time.

Table 9. *Pandalus borealis* in West Greenland: mean carapace length (mm) at age 2 in 2005–2024, with standard deviations and coefficients of variation (- : not present, (): fixed in the final MIX run, na: no data).

Year	Region/ Strata					
	U1-U3	I1+I2	C0	W1-W4	W5+W6	V7-W9/W10
	150-600 m	150-600 m	200-600 m	150-600 m	150-600 m	150-600 m
2005	11.1	11.5	-	12.5	-	-
2006	11.5	11.4	-	12.3	12.5	-
2007	-	11.5	-	-	12.5	-
2008	13.4	12.6	-	12.4	11.5	-
2009	12.2	11.8	-	12.3	12.2	-
2010	10.8	11.9	-	13.1	-	-
2011	-	11.2	na	11.3	-	-
2012	11.7	11.0	na	-	11.7	-
2013	11.2	13.1	-	13.5	13.0	-
2014	12.3	13.5	na	13.1	-	-
2015	11.5	13.4	na	12.1	12.0	-
2016	12.6	12.0	na	12.1	13.7	-
2017	11.5	11.8	na	11.0	11.2	-
2018	11.5	11.5	na	10.9	13.6	-
2019	10.2	12.1	na	10.9	12.2	-
2020	10.8	12.0	na	12.2	12.5	-
2021	-	-	-	-	-	-
2022	10.1	10.7	na	10.8	10.3	-
2023	9.6	11.5	na	10.5	11.3	-
2024	11.16	11.0	na	11.8	12.5	-

Standard deviation:

Year	Region/ Strata					
	U1-U3	I1+I2	C0	W1-W4	W5+W6	W7-W9
	150-600 m	150-600 m	200-600 m	150-600 m	150-600 m	150-600 m
2005	0.9	1.5	-	1.3	-	-
2006	1.0	1.1	-	1.4	1.3	-
2007	-	1.4	-	-	1.3	-
2008	1.7	1.9	-	1.3	0.8	-
2009	1.4	1.4	-	1.1	1.26	-
2010	1.3	1.2	-	1.3	-	-
2011	-	1.0	na	1.2	-	-
2012	1.5	1.1	na	-	0.4	-
2013	1.0	1.3	-	1.1	1.4	-
2014	1.0	1.4	na	1.4	-	-
2015	0.9	1.5	na	1.1	1.0	-
2016	1.3	1.5	na	1.9	0.9	-
2017	1.3	1.2	na	1.2	0.9	-
2018	1.1	0.9	na	1.2	1.3	-
2019	0.9	1.6	na	1.3	1.4	-
2020	0.5	1.4	na	1.0	1.1	-
2021	-	-	-	-	-	-
2022	1.0	1.1	na	1.1	0.8	-
2023	0.9	1.0	na	0.8	0.8	-
2024	1	0.9	na	1.6	0.6	-

Coefficient of variation:

Year	Region/ Strata					
	U1-U3	I1+I2	C0	W1-W4	W5+W6	W7-W9
	150-600 m	150-600 m	200-600 m	150-600 m	150-600 m	150-600 m
2005	0.08	0.13	-	0.10	-	-
2006	0.09	0.09	-	0.11	0.10	-
2007	-	0.12	-	-	0.11	-
2008	0.12	0.15	-	0.10	0.07	-
2009	0.11	0.12	-	0.09	0.11	-
2010	0.12	0.10	-	0.10	-	-
2011	-	0.09	na	0.10	-	-
2012	0.13	0.10	na	-	0.03	-
2013	0.09	0.10	-	0.08	0.11	-
2014	0.08	0.10	na	0.11	-	-
2015	0.08	0.11	na	0.09	0.08	-
2016	0.08	0.10	na	0.10	0.07	-
2017	0.10	0.09	na	0.11	0.08	-
2018	0.08	0.16	na	0.11	0.04	-
2019	0.07	0.16	na	0.12	0.03	-
2020	0.07	0.09	na	0.08	0.07	-
2021	-	-	-	-	-	-
2022	0.07	0.09	na	0.09	0.49	-
2023	0.08	0.10	na	0.09	0.49	-
2024	0.06	0.10	na	0.16	0.49	-

Table 10. *Pandalus borealis* in West Greenland: survey estimate of numbers (billions) at age 2 years, 1993–2024.

Year	U1 to U3	I1 and I2	C0 and W1 to W4	W5 and W6	W7- W9/W10	Total	
1993	0.06	0.08	2.60	1.54	0.00	4.28	
1994	0.01	0.21	1.51	1.20	0.00	2.92	
1995	0.02	0.11	0.82	1.37	0.00	2.32	
1996	0.11	1.25	2.45	6.20	0.00	10.01	
1997	0.05	1.37	0.52	1.27	0.00	3.22	
1998	0.04	1.79	2.01	2.60	0.00	6.44	
1999	0.42	5.06	2.66	3.22	0.00	11.36	
2000	0.33	5.54	4.92	3.50	0.01	14.29	
2001	1.66	5.44	7.79	1.01	0.01	15.90	
2002	0.02	3.98	3.41	2.97	0.04	10.42	
2003	0.76	1.11	1.70	2.88	0.03	6.48	
2004	0.64	3.39	2.24	0.47	0.01	6.75	
2005	0.32	3.47	0.23	0.05	0.00	4.07	
2006	0.33	1.86	2.12	0.78	0.00	5.09	
2007	0.00	0.96	0.00	0.00	0.38	0.00	1.34
2008	2.96	1.48	0.00	0.86	0.36	0.00	5.66
2009	1.95	2.05	0.00	0.91	0.14	0.00	5.05
2010	0.95	2.23	0.00	1.13	0.00	0.00	4.31
2011	0.00	2.52	-	0.44	0.00	0.00	2.96
2012	0.30	1.20	-	0.00	0.07	0.00	1.57
2013	0.40	2.03	0.00	1.63	0.00	0.00	4.06
2014	0.17	3.30	-	1.36	-	0.00	4.83
2015	1.38	3.62	-	5.35	0.50	0.00	10.85
2016	0.66	2.51	-	1.04	0.05	0.00	4.26
2017	0.24	1.18	-	1.43	0.18	0.00	3.03
2018	1.20	1.18	-	1.72	1.23	0.00	5.33
2019	0.43	0.35	-	0.35	9.42	0.00	10.55
2020	0.02	0.86	-	3.90	4.94	0.00	9.72
2021	-	-	-	-	-	-	-
2022	1.31	4.07	-	4.21	0.38	-	9.97
2023	0.23	0.99	-	0.40	2.27	-	3.90
2024	0.28	1.13	-	1.29	0.12	-	2.82
Average:	0.56	2.14	1.84	1.53	1.64	0.00	6.25

¹ data for 1993 to 2004 has been converted from Skervøy to Cosmos trawl;

² for area C0 – numbers of age 2 shrimps is in general very low. Estimating the components in the mixture distribution to the data using maximum-likelihood estimation for the grouped data, resulting is very poor fits.

* Numbers of age-2 shrimps from 2005 – 2014 have been recalculated in 2014.

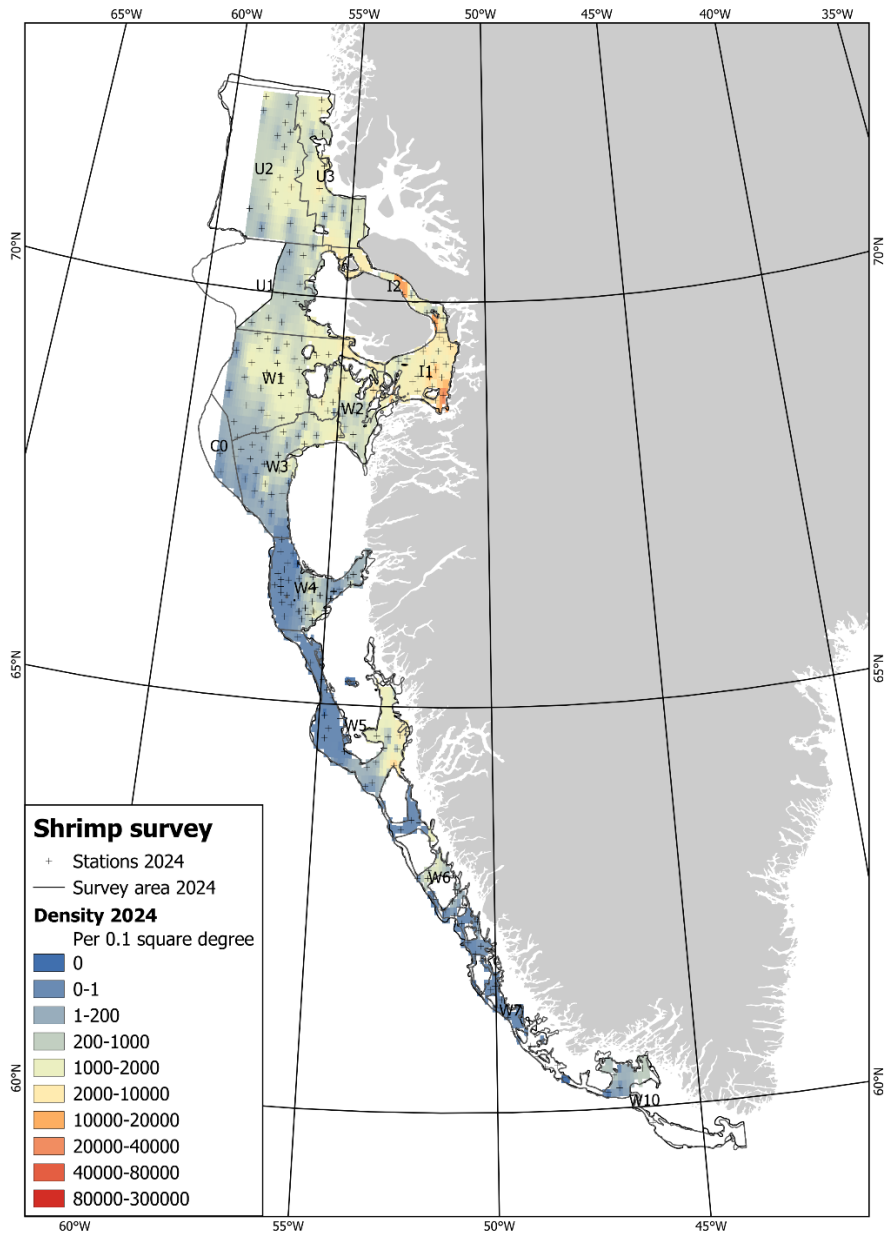

Figure 1. *Pandalus borealis* in West Greenland: density distribution from 291 trawl-survey stations in 2024.

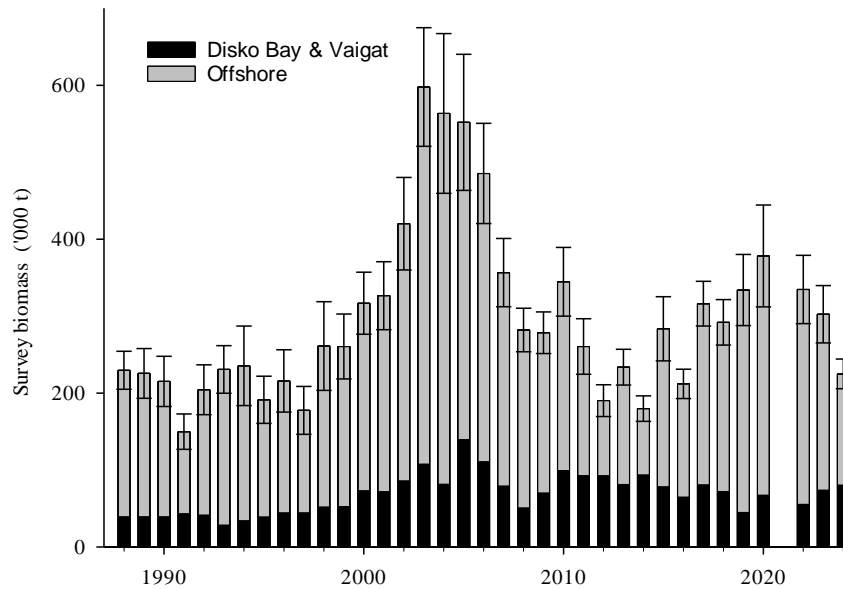

Figure 2a . *Pandalus borealis* in West Greenland: estimated survey biomass, 1988–2024. Area C0-4 was not surveyed in 2011 – 2016 and 2020, except 2013 because of ice cover, in 2014 W9-4 due to poor bottom conditions, area C0 in 2011, 2012, 2014-2016, 2018, 2020- 2023 due to ice cover and/or other priorities. In 2024 was it only possible to fish 2 stations in C0, due to the sea ice situation.

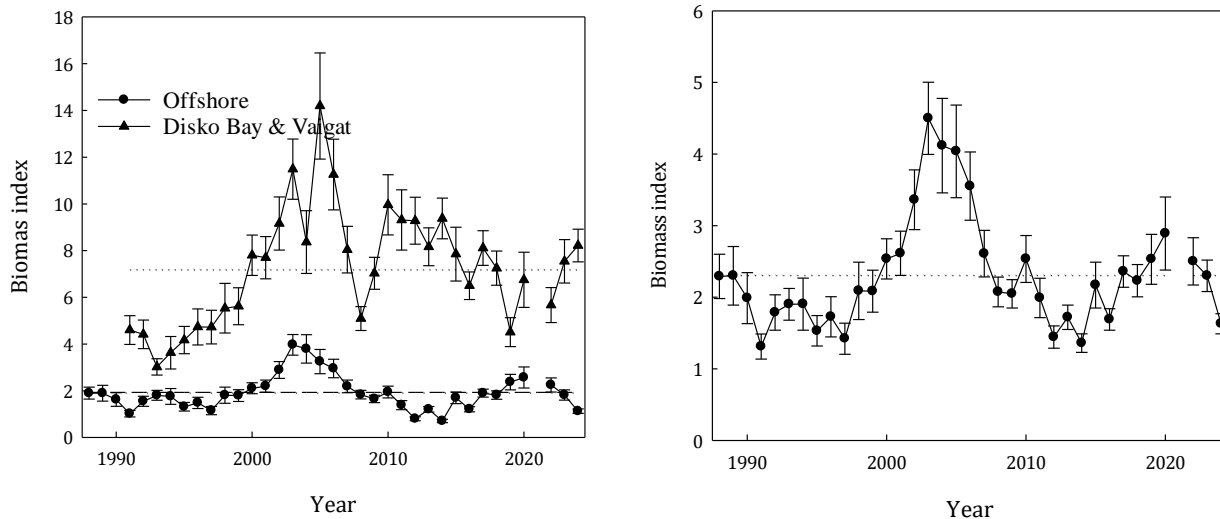

Figure 2 b. *Pandalus borealis* in West Greenland: distribution of survey biomass between major survey regions, 1991 – 2024.

Area C0 was not in 2011, 2012, 2014-2016, 2018, 2019 – 2023 owing to lack of ship time, other prioritization, and sea ice coverage.. In 2024 was it only possible to fish 2 stations in C0, due to the sea ice situation.

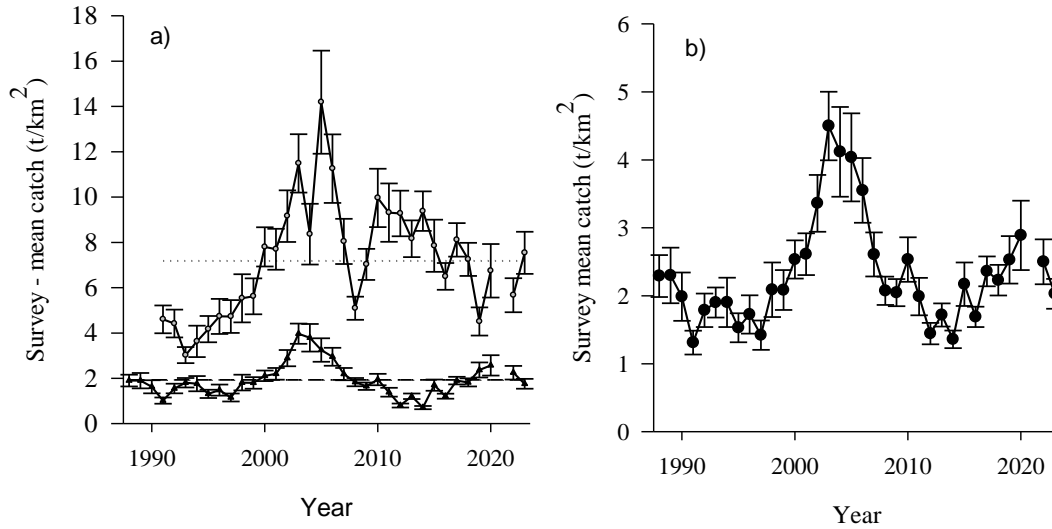

Figure 3. *Pandalus borealis* in West Greenland 1988 - 2024: mean survey density of Northern shrimp in a) -○- Disko Bay and Vaigat (since 1991 cover 7–8% of the survey area), -▲- offshore (92–93%) and b) total surveyed regions.

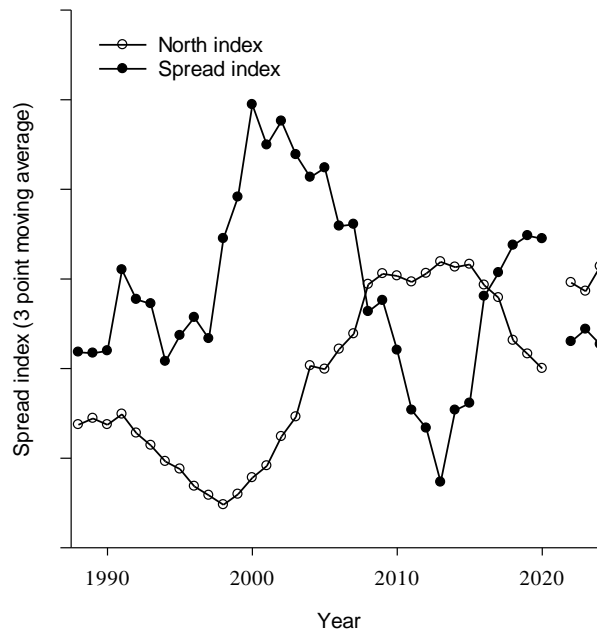

Figure 4. *Pandalus borealis* in West Greenland: indices of distribution and location of shrimp biomass in the West Greenland trawl survey 1994–2024 (3-point moving averages). -○-: North index (3-pt moving average) and -■-; Spread index (3-pt moving average).

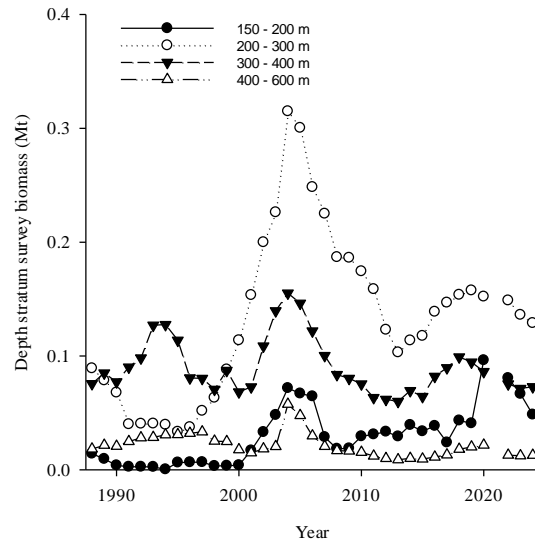

Figure 5a. *Pandalus borealis* in West Greenland: survey biomass estimates by depth stratum, 1988–2024. 3-point moving averages.; Until 2003, only areas C and W were substratified by depth. -●-: 150 – 200m, -○-: 200-300m, -▼-: 300-400 and -△- : 400-600m.

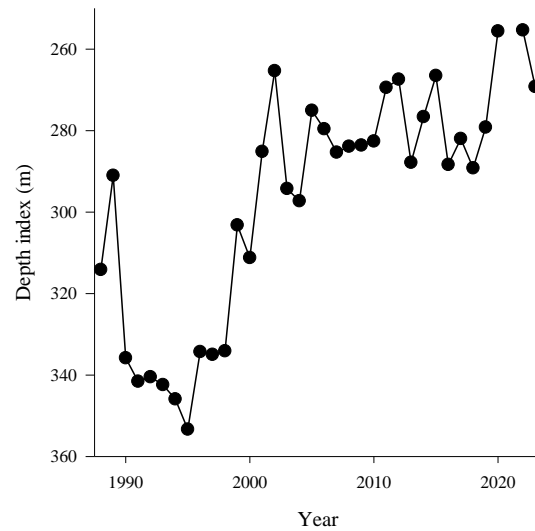

Figure 5b. *Pandalus borealis* in West Greenland: depth index for survey biomass, 1988–2024. Until 2003, only areas C and W, were substratified by depth.

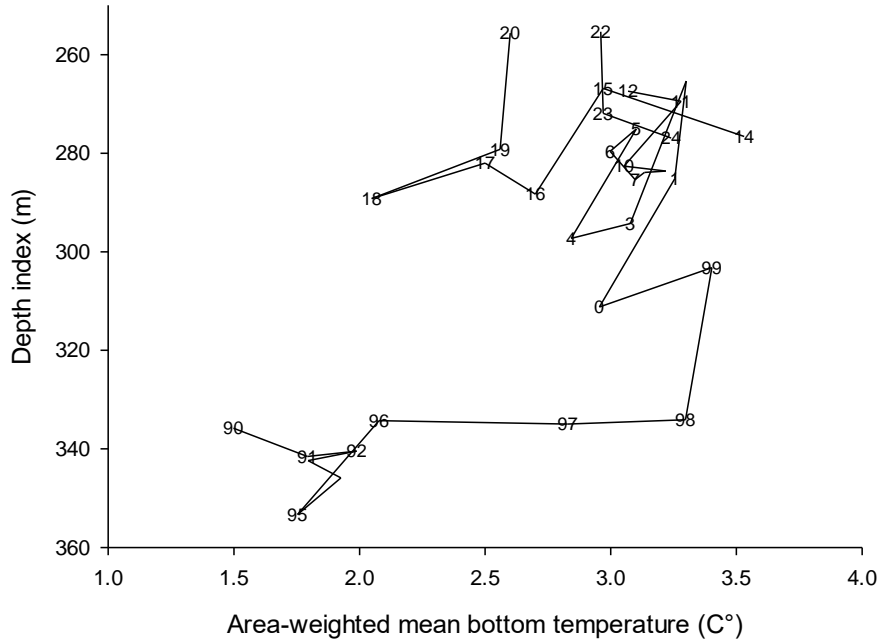

Figure 6. *Pandalus borealis* in West Greenland: depth index of survey biomass vs. area-weighted mean bottom temperature from survey trawl-door measurements, 1990–2024.

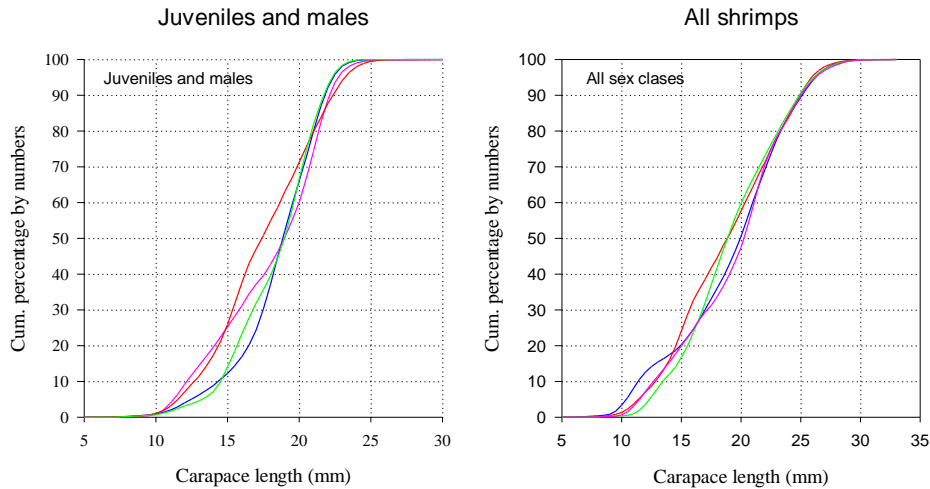

Figure 7. *Pandalus borealis* in West Greenland: distribution of lengths from survey length analyses in 2019 (pink line), 2020 (green line), 2022 (blue line) and 2023 (red line).

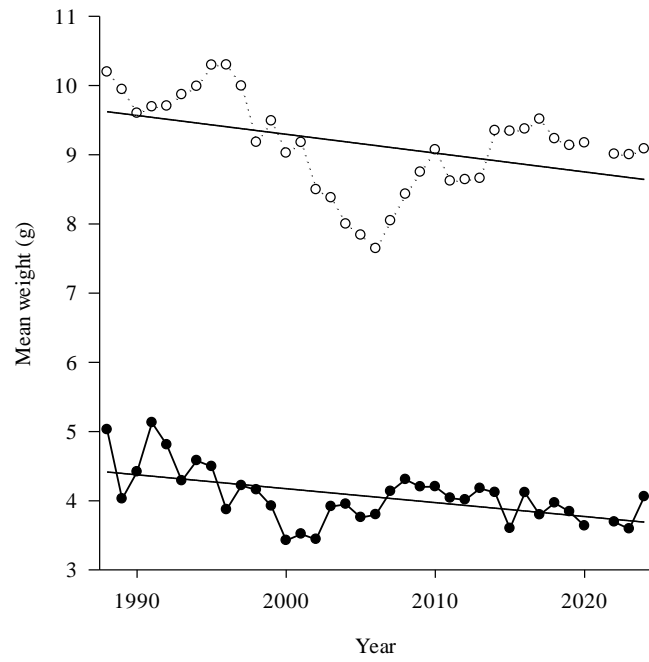

Figure 8. *Pandalus borealis* in West Greenland: mean weight by sex, from survey data, 1988–2024.

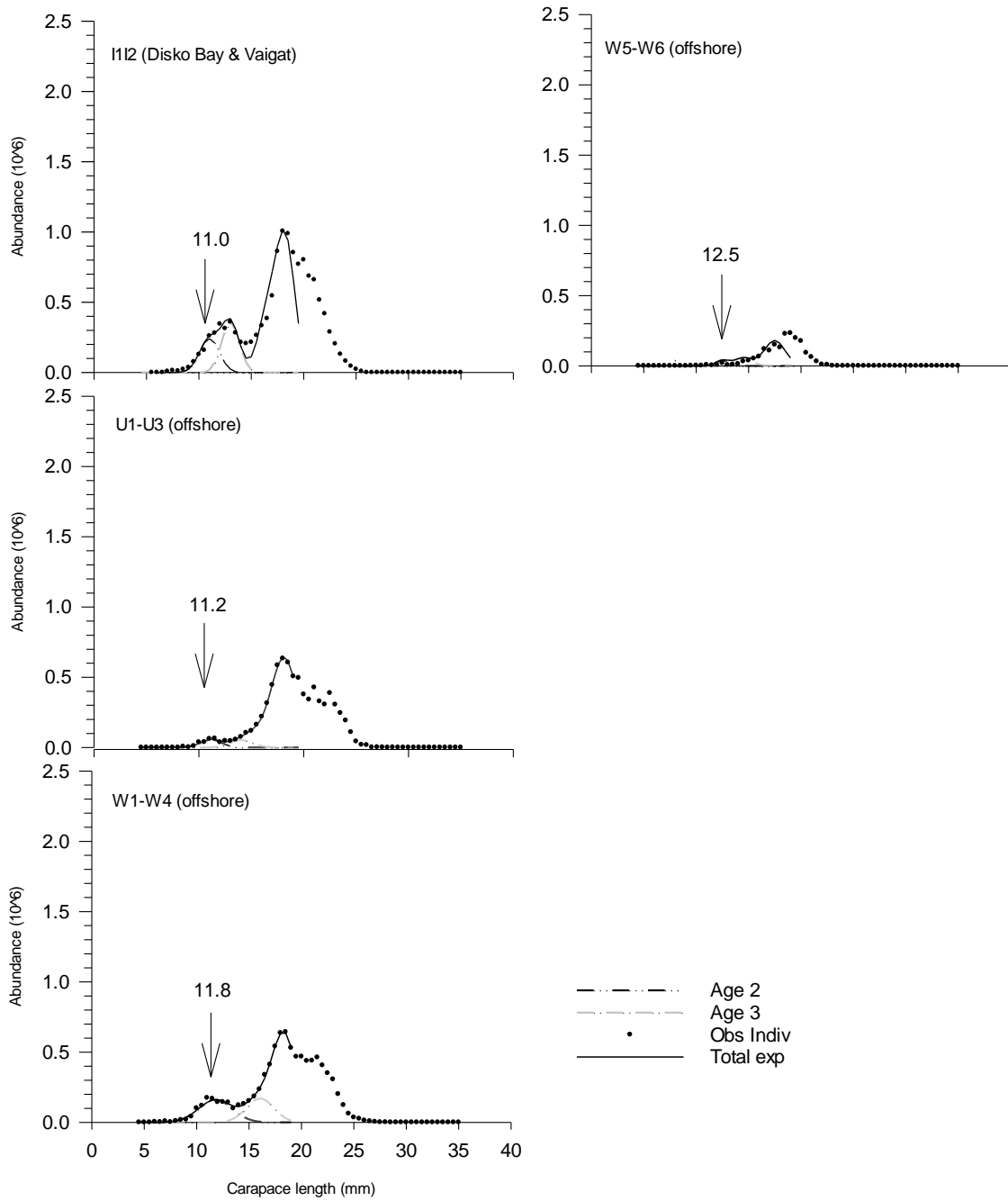

Figure 9. *Pandalus borealis* in West Greenland: regional length frequencies in 2024.

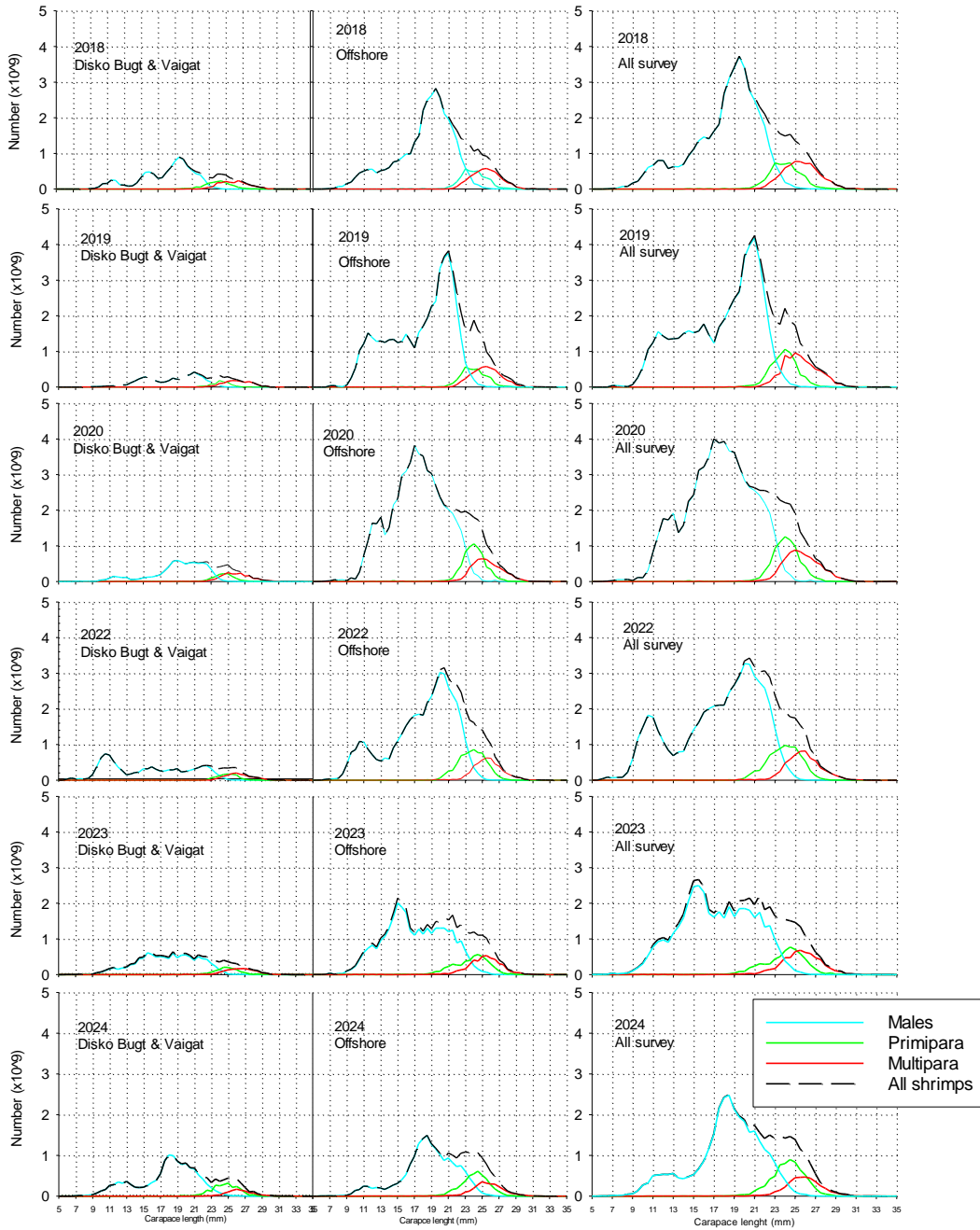

Figure 10. *Pandalus borealis* in West Greenland: length frequencies offshore, in Disko Bay and Vaigat, and overall, 2018-2024.

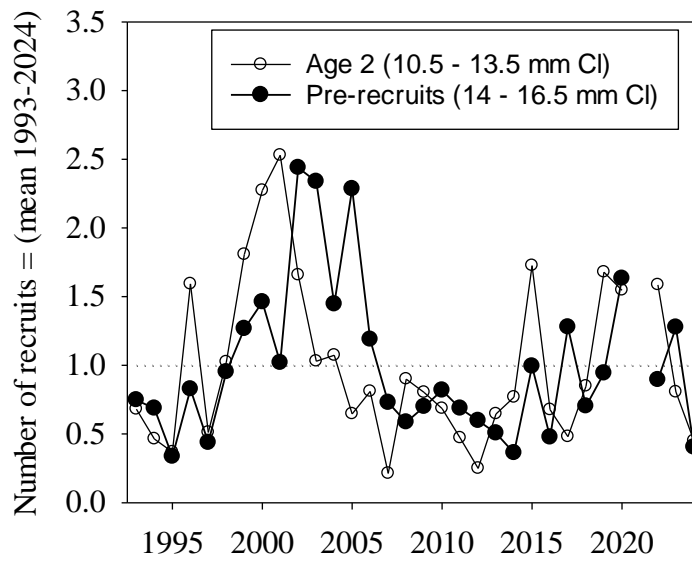

Figure 11. *Pandalus borealis* in West Greenland: index of numbers at age 2 and pre-recruits, 1993–2024.

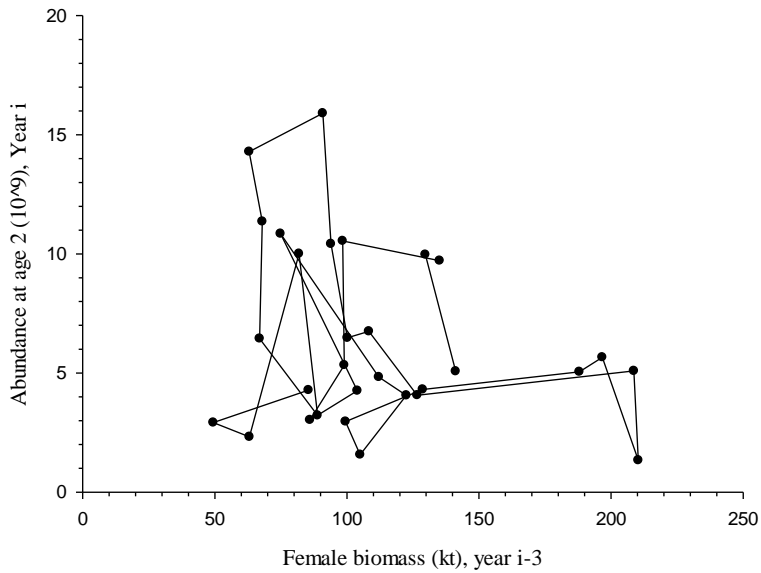

Figure 12. *Pandalus borealis* in West Greenland: survey estimates of numbers at age 2 in 1993–2024 against female biomass 3 years earlier (labels denote years in which age-2 numbers were estimated).

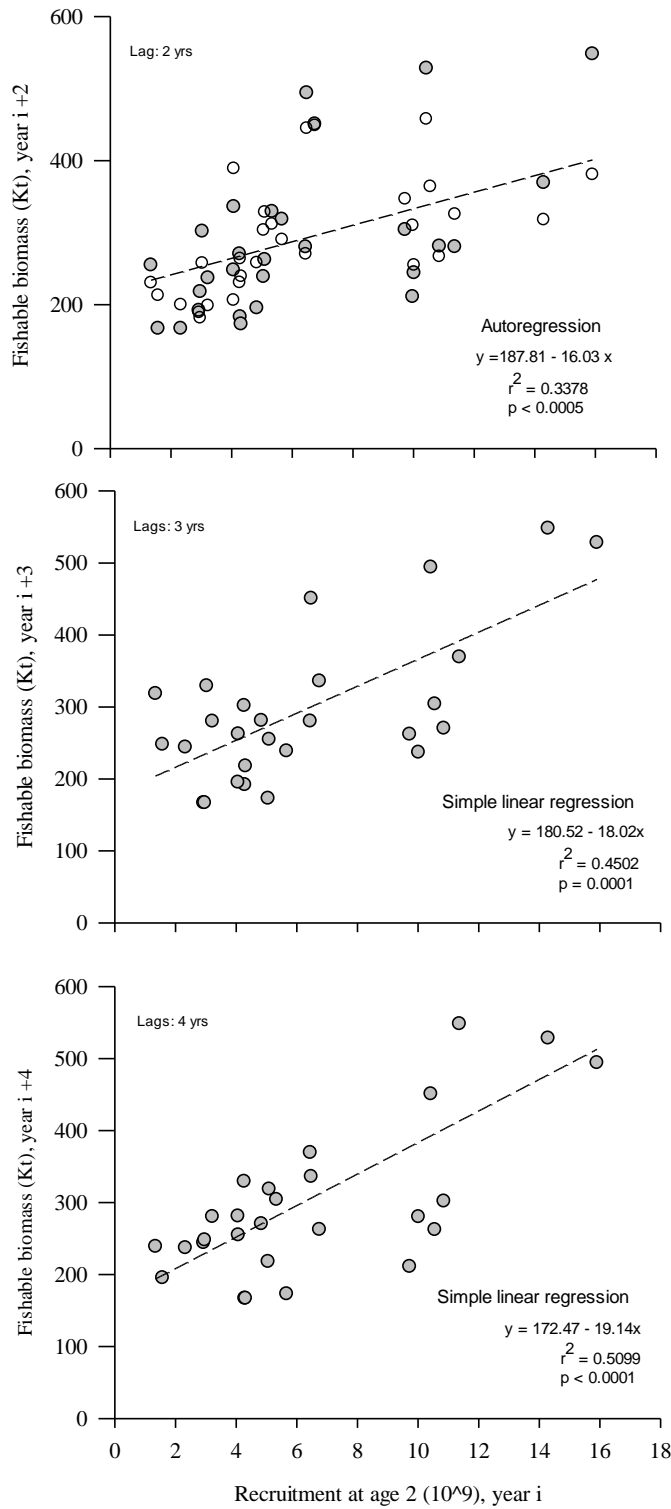

Figure 13. *Pandalus borealis* in West Greenland: lagged fishable biomass vs. survey estimates of numbers at age 2 from 1993 to 2024 (autocorrelated regressions lags: 2 years; open circles predicted values from autoregression).

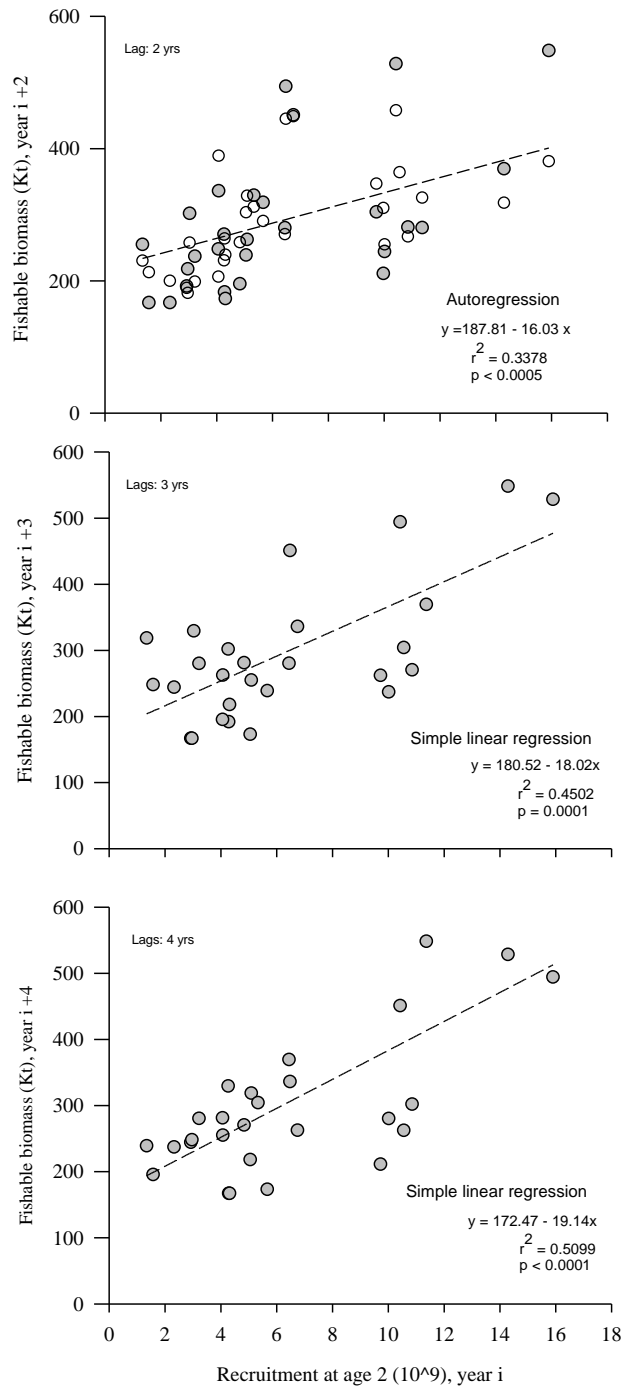

Figure 14. *Pandalus borealis* in West Greenland: area-weighted mean bottom temperature for survey regions (see Fig. 1 for locations), depth strata in offshore areas C and W1–W7, and the entire survey area in 1990–2024.

Appendix 1:

Grønlands Naturinstitut

Greenland Institute of Natural Resources
 R/V Paamiut
 OYZC – GR6-251
 MMSI 331 102 00
 engine.paamiut@gmail.com

Statement regarding using M/Tr Sjørðarberg to carry out the same surveys as R/V Paamiut

In November 2017 R/V Paamiut failed to comply with DNVGL standards for working in Arctic waters. The management of Greenland Institute of Natural Resources (GN) decided not to spend more money on the vessel, but to go for building a new ship.

For the 2018-season, GN decided to charter Sjørðarberg, a Faroese trawler of almost same dimensions as Paamiut, doing the normal surveys on the Greenland west coast.

To make the surveys as identical as possible this equipment was used from R/V Paamiut:

- Cosmos trawls
- All other equipment, such as bridles etc.
- Doors
- Marport sensors on doors and headline

Other steps taken ensuring the validity of received data:

- The wires/warps on Sjørðarberg were same dimension (26mm) as used on Paamiut
- The distance between the hanging blocks was the same
- The Marport equipment on the bridge was set up and calibrated as on Paamiut
- All data from the tows were logged as normal procedure on Paamiut
- Skipper on Paamiut (Birgir Sivertsen) was on the bridge as supervisor, taking care of that all of the trawling was carried out as on Paamiut
- Chief Engineer from Paamiut was on board ensuring that all technical equipment performed as normal
- Crew from Paamiut worked together with the rest of the crew, ensuring that all maintenance of trawls etc. were carried out exactly as normal

To my best conviction regarding comparism, the surveys were executed in the best possible way, and I have absolutely no thoughts that this could be done otherwise or better.

Best regards

Kári Hansen, Chief Engineer

Grønlands Naturinstitut

Greenland Institute of Natural Resources

R/V Paamiut

OYZC – GR6-251 MMSI 331 102 00 engine.paamiut@gmail.com

Statement regarding using M/Tr Helga Maria to carry out the same surveys as R/V Paamiut for 2019

In November 2017 R/V Paamiut failed to comply with DNVGL standards for working in Arctic waters. The management of Greenland Institute of Natural Resources (GN) decided not to spend more money on the vessel, but to go for building a new ship.

For the 2019-season, GN decided to charter Helga Maria, a Icelandic trawler of almost same dimensions as Paamiut, doing the normal surveys on the Greenland west coast and Canada east coast.

To make the surveys as identical as possible this equipment was used from R/V Paamiut:

Alfredo trawls with 96 mtr bridles, as with R/V Paamiut

Cosmos trawls with 48 mtr bridles, as with R/V Paamiut

- All other equipment, such as bridles ,gear etc.
- Doors
- Marport sensors on doors and headline

Other steps taken ensuring the validity of received data:

- The wires/warps on Helga Maria were same dimension (26mm) as used on Paamiut
- The distance between the hanging blocks was the same
- The Marport equipment on the bridge was set up and calibrated as on Paamiut
- All data from the tows were logged as normal procedure on Paamiut
- Skipper on Paamiut (Jakup G.Mikkelsen) and Chief Engineer Kari Hansen was on Island ,used 14 days onboard Helga Maria, before departure to Greenland, to prepare and make the right arrangement on deck and factory for trawl equipment, and what else the Scientifics need, to make the surveys as similar as possible compare with R/V Paamiut. Skipper Jakup G.Mikkelsen also was onboard for one month, working on the bridge and deck as supervisor, taking care of that all of the trawling and equipment was carried out as on Paamiut
- Crew from Paamiut worked together with the rest of the crew, ensuring that all maintenance of trawls etc. were carried out exactly as normal

To our best conviction regarding comparison, the surveys were executed in the best possible way, and we have absolutely no thoughts that this could be done otherwise or better.

Best regards

Jakup G Mikkelsen Kari Hansen
Captajn Chief Engineer 1

Grønlands Naturinstitut

Greenland Institute of Natural Resources

R/V Paamiut

OYZC - GR6-251 MMSI 331 102 00 engine.paamiut@gmail.com

**Statement regarding using M/Tr Helga Maria to carry out the same surveys as R/V Paamiut for 2020**

In November 2017 R/V Paamiut failed to comply with DNVGL standards for working in Arctic waters. The management of Greenland Institute of Natural Resources (GN) decided not to spend more money on the vessel but decided instead to build a new ship.

For the 2020-season, GN decided to charter Helga Maria, a Icelandic trawler of almost the same dimensions as Paamiut, doing the normal surveys on the Greenland west and east coast.

M/V Helga Maria was also chartered for the 2019-season by GN to great satisfaction for good work.

To make the surveys as identical as possible this equipment was used from R/V Paamiut:

Cosmos trawls with 48 mtr bridles, as with R/V Paamiut

- All other equipment, such as bridles, gear etc.
- Doors
- Marport sensors on doors and headline

Other steps taken to ensure the validity of received data:

- The wires/warps on Helga Maria were the same dimension (26mm) as used on Paamiut
- The distance between the hanging blocks was the same
- The Marport equipment on the bridge was set up and calibrated as on Paamiut
- All data from the tows were logged as normal procedure on Paamiut
- Skipper on Paamiut (Jakup G.Mikkelsen) and Chief Engineer Kari Hansen were on Iceland. They spent 10 days onboard Helga Maria, before departure to Greenland, to prepare and make the right arrangement on deck and factory for trawl equipment, and what else the Scientists need, to make the surveys as similar as possible compare with R/V Paamiut.

The trawl bass Boas Augustussen, former deck hand from Paamiut, was onboard the whole journey, taking care of all of the trawl and equipment. He worked together with the rest of the crew, ensuring that all maintenance of trawls etc. were carried out exactly as onboard Paamiut.

The same captain onboard Helga Maria from the 2019 survey, was also onboard the 2020 survey. He also took care of all of the trawling and equipment. This was carried out as on board Paamiut.

To our best conviction regarding comparison, the surveys were executed in the best possible way, and we have absolutely no thoughts that this could be done otherwise or better.

Best regards

Jakup G Mikkelsen

Captain

Kari Hansen

Chief Engineer

Grønlands Naturinstitut , Greenland Institute of Natural Resources
R/V Tarajoq

OYLD -IMO 9881225- MMSI 331983000 -tarajoq.bridge@natur.gl



Statement regarding using R/V Tarajoq to carry out the same surveys as R/V Paamiut for 2022

In November 2017 R/V Paamiut failed to comply with DNVGL standards for working in Arctic waters. The management of Greenland Institute of Natural Resources (GN) decided not to spend more money on the vessel, but decided instead to build a new ship.

For the 2020-season, GN decided to charter Helga Maria, a Icelandic trawler of almost the same dimensions as Paamiut, doing the normal surveys on the Greenland west and east coast.

M/V Helga Maria was also chartered for the 2019-season by GN to great satisfaction for good work.

All the fishing equipment on board Tarajoq is new but made according to exactly the same teas that R/V Pamiut has used for more than 20 years. This means that fishing doors and cosmos trawls, Rockhopper gear, 48 mtr bridles are exactly the same. The net is made according to the same dimensions that have been used for the last 20 years.

To make the surveys as identical as possible this equipment is used onboard R/V Tarajoq.

Cosmos trawls with 48 mtr bridles, as with R/V Paamiut

- All other equipment, such as bridles, gear etc.
- Doors
- Marport sensors on doors and headline

Other steps taken to ensure the validity of received data:

- The wires/warps on R/V Tarajoq is the same dimension (26mm) as used on Paamiut
- The Marport equipment on the bridge is set up and calibrated as on Paamiut
- All data from the tows is logged as normal procedure on Paamiut
- Captain Jakup, Chief Engineer Kari and trawl bass Boas , from the old crew aboard Pamiut, is also with the new crew aboard Tarajoq.
- We have been very careful to have all fishing equipment and rigging the same as with Pamiut, to prepare and make the right arrangement on deck and factory for trawl equipment, and what else the Scientists need, to make the surveys as similar as possible compare with R/V Paamiut.

To our best conviction regarding comparison, the surveys for 2022 were executed in the best possible way, and we have absolutely no thoughts that this could be done otherwise or better.

Best regards

Jakup G Mikkelsen

Captain

Kari Hansen

Chief Engineer

29-08-2022